

INSTALLATION GUIDE AND USER MANUAL

L3 SERIES LIMITLESS LITHIUM™

L3 HV-40kWh | L3 HV-60kWh





READ THE INSTRUCTIONS COMPLETELY BEFORE OPERATING THE EQUIPMENT

While a best effort is made to ensure all specifications and descriptions contained in this document are accurate at the time of publication, Sol-Ark reserves the right to make product modifications at any time without advance notice.

For the latest Sol-Ark product and installation documents, visit: www.sol-ark.com

For errors, omissions, or suggestions, contact support@sol-ark.com

For complete product specifications and information on relevant product listings and certifications, refer to the Product Datasheet available at www.sol-ark.com



DISCLAIMER

UNLESS SPECIFICALLY AGREED TO IN WRITING:

Sol-Ark assumes no responsibility or liability for any damages, property loss, personal injury, or any adverse consequences resulting from improper use and installation of the product or the failure to adhere to the guidelines provided in this document. Users are expressly advised to follow the instructions and guidelines outlined in the documentation accompanying the product. Sol-Ark shall not be liable for any damages or losses incurred due to deviations from recommended usage, installation, or maintenance procedures. By using the product, users acknowledge their understanding of these disclaimers and agree to use the product at their own risk. Sol-Ark reserves the right to update or modify product information, specifications, and guidelines without prior notice.

Sol-Ark retains the right to final interpretation of this document and all related materials pertaining to this product. This document is subject to modifications, updates, revisions, or termination without prior notice. For the latest product information, please visit Sol-Ark's official website. www.sol-ark.com

This manual is only for the **L3 Series Limitless Lithium™ Indoor Battery Energy Storage System**.

For support, contact:

(USA) +1 (972) 575-8875 ext. (2)

support@sol-ark.com

Table of Contents

IMPORTANT INSTRUCTIONS.....	4
1. L3 Series: First Glance.....	6
1.1 General Description.....	7
1.2 Specifications.....	8
2. Installation.....	11
2.1 Part List.....	11
2.2 Assembly.....	12
2.3 Equipment Clearance Guidelines.....	15
2.4 Seismic Installation Guidelines.....	15
2.5 Battery Overview.....	16
2.5 Wiring.....	17
2.6 Battery Communications.....	19
2.7 Powering-up the Sol-Ark L3 System.....	20
2.8 Power Cycle Sequence.....	20
3. User Interface.....	21
3.1 HMI Screens.....	21
3.2 System Setup.....	22
4. Operation and Maintenance.....	23
4.1 Maintenance of the L3 system.....	23
4.2 Fire Suppression System.....	23
4.3 Over-Discharge Recovery.....	23
4.4 HMI Firmware Update Process.....	24
4.5 BMS Firmware Update Process.....	24
4.5 Long Term Battery Storage.....	25
4.7 Wiring Diagrams.....	26
5. Error Codes.....	28
5.1 Description of System Faults.....	28
5.2 Common Causes.....	29

IMPORTANT INSTRUCTIONS

This manual provides crucial information for the installation and operation of the L3 Series Limitless Lithium™ Battery Energy Storage System. Qualified and authorized personnel are required to conduct the installation and maintenance procedures adhering to all safety standards and system requirements outlined in this document.

This manual is applicable to countries that comply with the certification requirements. Standards and legal requirements of other countries might differ from the specifications outlined in this manual.

To secure the full product warranty, the L3 system must be registered by completing the warranty verification process and sending the information to Sol-Ark.

SYMBOLS THAT APPEAR IN THIS DOCUMENT

 **WARNING:** This symbol indicates information that, if ignored, could cause serious injury, equipment damage, or death.

 **CAUTION:** This symbol indicates information that, if ignored, could result in minor injury or equipment damage.

 **NOTE:** This symbol indicates relevant information that is not related to hazardous situations.

SYMBOLS THAT APPEAR ON THE EQUIPMENT

 **CAUTION:** Indicates risk of injury or equipment damage.

 **RISK OF ELECTRIC SHOCK:** Indicates components that present risk of electrical shock.

 **DO NOT INCINERATE:** Do not dispose of product by incineration.

 **RISK OF EXPLOSION:** Physical damage, fire, or over charging may cause Li-ion batteries to ignite and/or explode.

 **RECYCABLE:** Product is recyclable. Proper disposal is required.

 **REFER TO INSTRUCTIONS:** User must refer to operating and installation instructions before proceeding.

 **cSGSus:** SGS marking indicates NRTL product testing and certification for compliance with standards for North America and Canada.

 **DO NOT THROW AWAY:** Proper disposal of inverters and/or batteries is required

NOTICES

ATTENTION: Read all instructions and cautionary markings in this document and on the equipment before installing the L3 HV. Failure to do so may result in equipment damage, electric shock, serious injury, or loss of life. Failing to follow any of these instructions may also void the warranty.

All installations must conform to the laws, regulations, codes and standards applicable in the jurisdiction of installation. Before starting an installation, consult a local building or electrical inspector for current requirements. Local codes may vary but are adopted and enforced to promote safe electrical installations. A permit may be needed to do electrical work, and some codes may require an inspection of the electrical work.

When installed in the US electrical installations are required to follow the National Electrical Code (ANSI/NFPA 70) adopted by their local AHJ (Authority Having Jurisdiction) including any local amendments.

General

WARNING: Risk of electric shock. Risk of fire. Only qualified electrical personnel should install, troubleshoot, service, or replace the equipment.

WARNING: Risk of electric shock. Apply appropriate personal protective equipment (PPE) and follow safe electrical work practices during installation and service. Turn off all power supplying this equipment before working on or inside equipment. Always use a properly rated voltage sensing device to confirm

power is off. Replace all devices, covers, and doors before turning on power to the equipment.

WARNING: Inspect the equipment for damage before installing. Do not install the equipment if it has been damaged in any way.

WARNING: Do not insert foreign objects into any part of the equipment.

WARNING: Do not expose the equipment or any of its components to direct flame.

WARNING: Do not attempt to open, disassemble, repair, tamper with, or modify the equipment other than what is permitted in this manual. The equipment contains no user-serviceable parts. Contact the installer who installed the equipment for any repairs.

WARNING: Do not connect life-support systems, other medical equipment, or any other use where product failure could lead to injury to persons or loss of life.

CAUTION: Do not use solvents to clean the equipment or expose the equipment to flammable or harsh chemicals or vapors. Do not allow petroleum-based paints, solvents, or sprays to contact nonmetallic parts of the equipment.

CAUTION: Do not use parts or accessories other than those specified for use with the equipment.

Installation and Use

WARNING: Risk of electric shock. Risk of fire. Only use electrical system components approved for dry locations.

WARNING: Risk of electric shock. Risk of fire. Ensure that all wiring is correct and that none of the wires are pinched or damaged.

WARNING: Risk of electric shock. Risk of fire. Before making any connections verify that the DC disconnect(s) are in the off position. Double check all wiring before applying power.

WARNING: Risk of electric shock. Improper servicing of the equipment or its components may result in a risk of shock or fire. To reduce these risks, disconnect all wiring before attempting any maintenance or cleaning.

WARNING: Risk of electric shock. Always de-energize the equipment before servicing.

WARNING: Risk of electric shock. Do not use equipment in a manner not specified by the manufacturer. Doing so may cause injury or loss of life, or damage to equipment.

NOTE: This device complies with part 15 of the FCC Rules. Operation is subject to the following two conditions: (1) This device may not cause harmful interference, and (2) this device must accept any interference received, including interference that may cause undesired operation. Changes or modifications not expressly approved by the party responsible for compliance could void the user's authority to operate the equipment.

Environmental Conditions

WARNING: This equipment is intended for operation in an environment having a minimum temperature of 4°C (40°F) and a maximum temperature of 43°C (110°F).

WARNING: Install the equipment in a location that prevents damage from flooding. Ensure that no water sources are above or near the equipment, including downspouts, sprinklers, or faucets.

NOTICES: Transportation and Handling

WARNING: To protect the equipment and its components from damage when transporting, handle with care. To help prevent damage, leave all equipment in its shipping packaging until it is ready to be installed.

WARNING: Risk of physical injury or death. The battery rack is not designed for transportation with modules installed. Do not attempt to lift a fully installed rack using any lifting device.

WARNING: Risk of physical injury or death. Vehicles used to transport Lithium-ion batteries must comply with all DOT transportation regulations surrounding Class 9 hazardous freight.

WARNING: Risk of physical injury or death. Use caution when using lifting equipment to move battery modules and components.

WARNING: Risk of physical injury or death. Boxed battery modules stacks should not exceed 8 units.

WARNING: Risk of physical injury or death. Each battery module weighs 44 kg (97lbs). Use appropriate transport and lifting equipment for safe handling and transport.

WARNING: Risk of physical injury or death.

Product Recycling

Due to the considerable size, the L3 HV series battery storage system requires special handling to be recycled properly. For more information on locating recycling resources in your area, please visit our website at sol-ark.com/recycling.

Proper recycling is crucial for lithium storage batteries. It keeps hazardous waste out of landfills and allows reusable materials like lithium and other metals to be recovered and repurposed. As the owner of the system, you are responsible for ensuring proper end-of-life recycling takes place through a certified lithium battery recycling program.

You must not attempt disposal via normal waste collection or abandon the battery at a public facility. Please reference our website or call us for more details as soon as you know your energy storage system has reached its end of usable life.



Li-ion



Requirements for Installation Personnel

All work MUST comply with local code, regulations, and industry standards. The installation of the L3 system can only be completed by qualified persons with appropriate qualifications as determined by the local AHJ.

1. L3 Series: First Glance

INSPECT SHIPMENT

The box should include all items shown in the component guide. If there are damaged or missing parts, immediately call Sol-Ark customers support at +1 (972) 575-8875 Ext. 2.

COMPONENT GUIDE

The L3 battery energy storage system includes the following components:

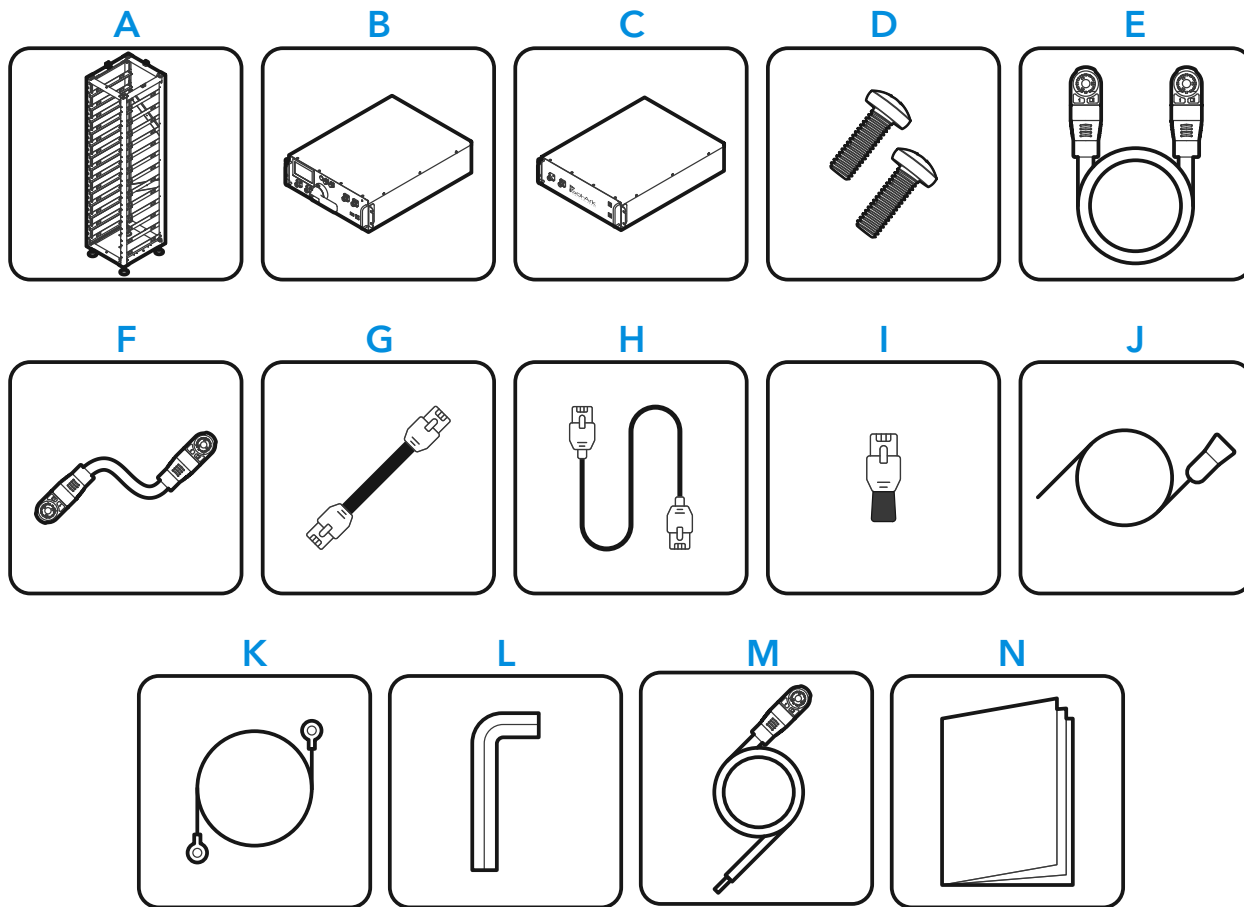

Component	Description	Quantity	
		L3 HV-40kWh	L3 HV-60kWh
A	Battery Rack and Components (unassembled)	See section 2.1	
B	L3 HV BMS 750V Battery Management System (BMS) Unit	1	
C	L3 HV 5.1kWh Battery Module	8	12
D	Module Rack Mount Screws (M4x20)	90	100
E	4AWG PushLok – Module to BMS Negative Cable	1	
F	4AWG PushLok– Module Series Jumper	8	12
G	Battery module communication cable	8	12
H	Inverter communication cable	1	
I	120Ω RJ45 terminating resistor	1	
J	External 12V power supply cord	1	
K	Battery rack grounding wire	1	
L	Battery Rack Screws Hex Key (4 mm)	1	
M	4AWG PushLok – BMS to Inverter Cable (positive/negative)	2	
N	Printed Documentation (some models)	1	

1.1 General Description

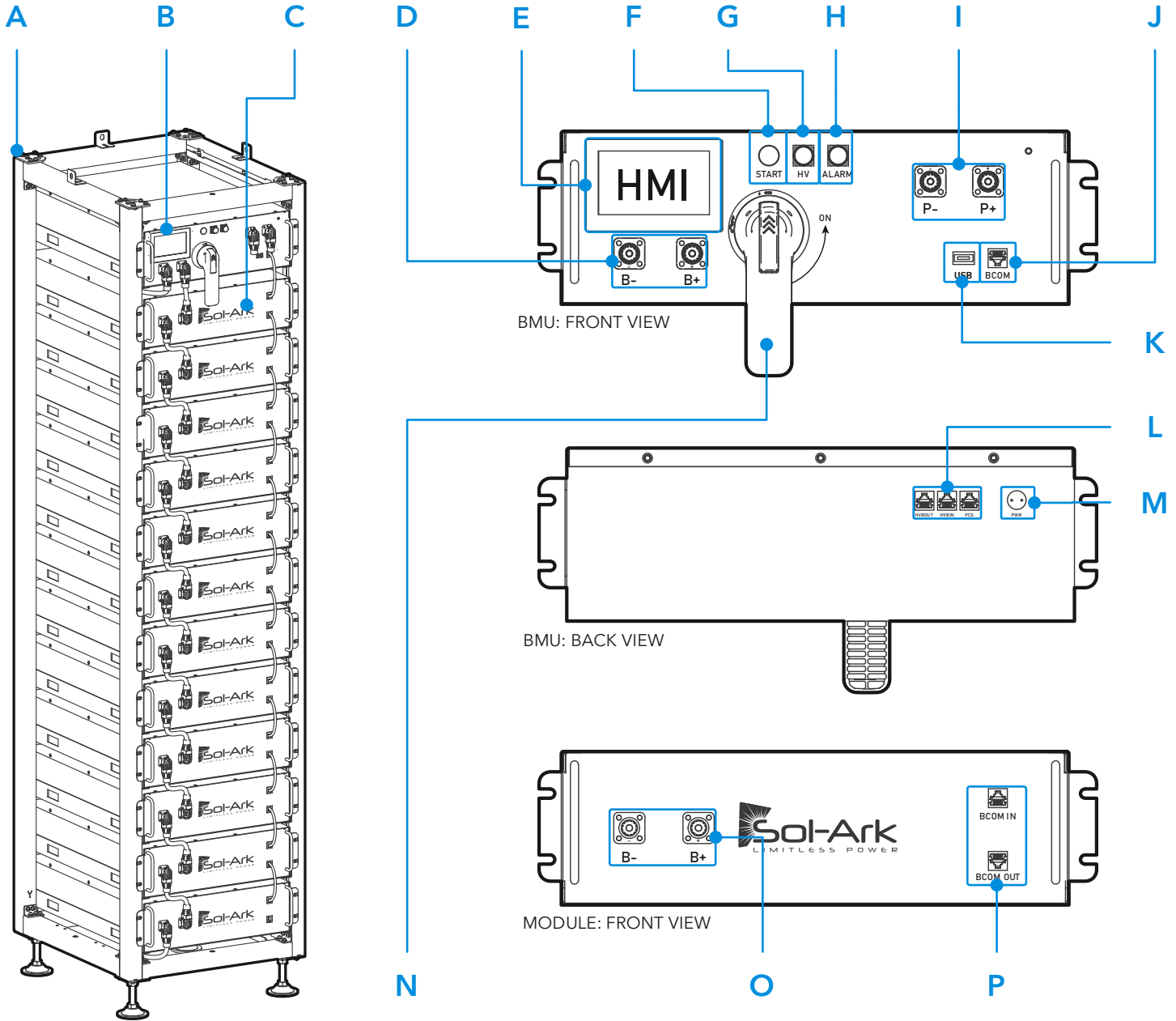

Component	Name	Component	Name
A	Battery Rack	I	Inverter (+, -) Connections
B	Battery Management System Unit (BMS)	J	BMS to Module Internal Communication port
C	Battery modules	K	BMS USB Upgrade Interface
D	BMS Battery (+, -) Connections	L	BMS Communication Ports
E	HMI Touchscreen	M	External 12V _{DC} Power Supply Input
F	BMS Start Button	N	200A Dual Pole, BMS DC Disconnect Switch
G	High Voltage Indicator	O	Battery Module (+, -) Connections
H	Alarm Indicator	P	Module-to-Module Internal Communications Ports

1.2 Specifications

L3 HV-60kWh Dimensions

NOTICE: Note that size and dimensions of the following drawing of the L3 energy storage systems corresponds to the L3 HV-60kWh model

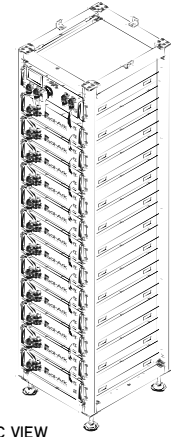
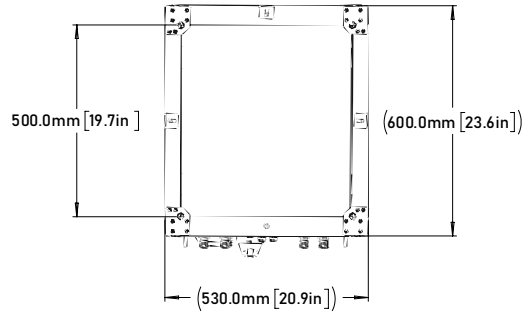

ISOMETRIC VIEW
REFERENCE ONLY

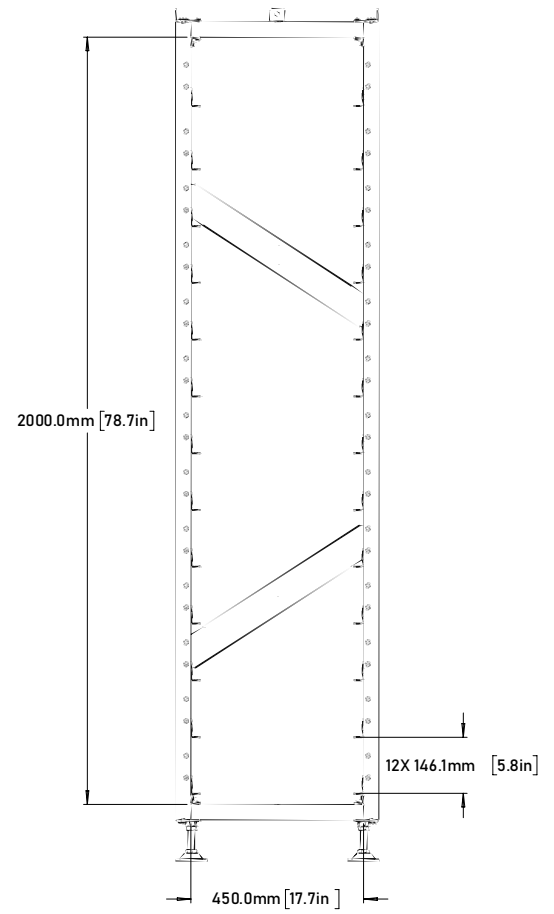
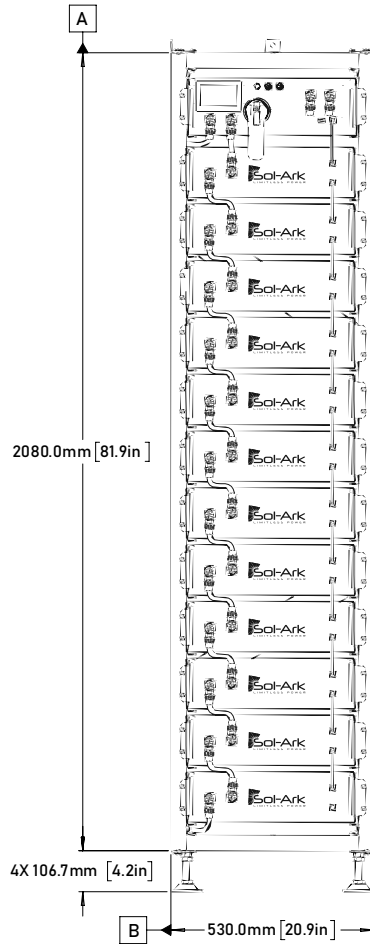
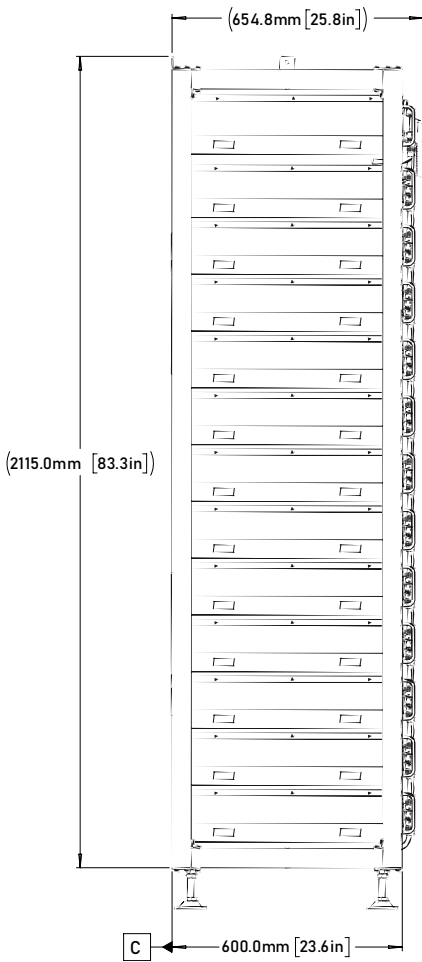

L3 HV-40kWh Dimensions



NOTICE: Note that size and dimensions of the following drawing of the L3 energy storage systems corresponds to the L3 HV-40kWh model

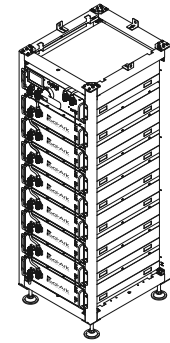
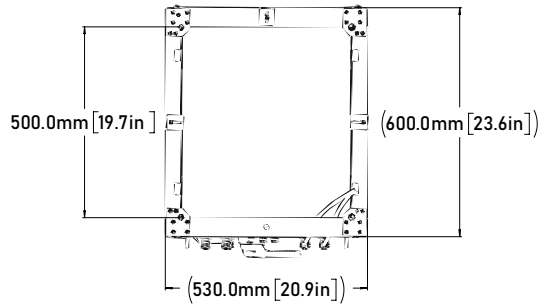

ISOMETRIC VIEW
REFERENCE ONLY

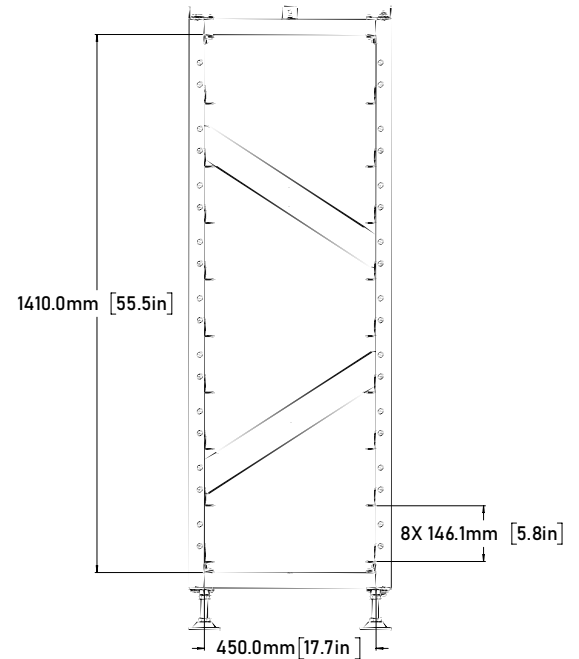
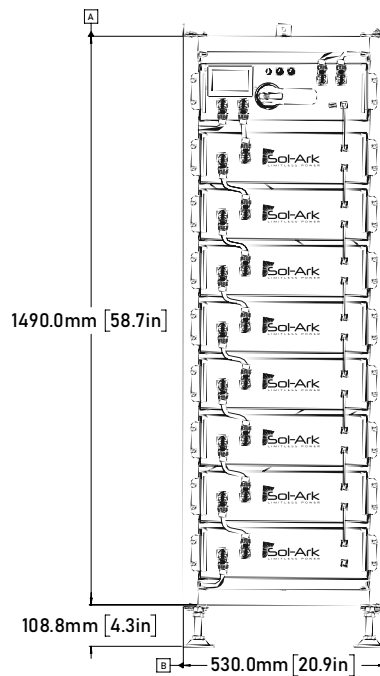
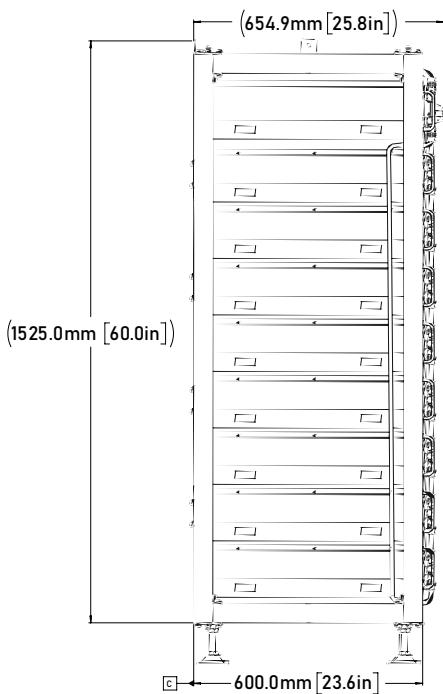

LIMITLESS LITHIUM™ L3 HV FASTENER TORQUE TABLE



Do not use impact drivers to tighten any fasteners on the inverter

Connection	Torque [in-lb]	Torque [Nm]
BMU/Rack Grounding Screw	40 in-lb	4.5 Nm
BMU Mounting Screws	10.6 in-lb	1.2 Nm
Battery Module Mounting Screws	10.6 in-lb	1.2 Nm

DATASHEET

L3 SERIES LIMITLESS LITHIUM™

INDOOR

Battery Energy Storage System

Battery Model:
SKU:

L3 HV-60kWh
L3-HV-60KWH-60K

L3 HV-40kWh
L3 HV-40KWH-30K

System Data

Compatible Inverter	Sol-Ark 60K-3P-480V-N	Sol-Ark 30K-3P-208V-N
Cell Chemistry	Lithium Iron Phosphate	
Nameplate Energy Capacity (DC)	61.44 kWh	40.96 kWh
Usable Energy Capacity (DC) ¹	55.30 kWh	36.86 kWh
Built-In DC Disconnect Rating	200A	
Internal Fuse Rating	160A	
Max. # Battery Units Per Inverter	16	
Max. # Inverters in Parallel	10	
Warranted Depth of Discharge	90%	
Roundtrip Efficiency Charge/Discharge (DC)	94% (25C, 0.5C)	
System Nominal Voltage (DC)	614.4V	410V
System Operating Voltage (DC)	588V – 672V	392V – 448V
Battery Pack Internal Configuration	12S1P	8S1P
Charge/Discharge Current ²		
• Recommend	50A	
• Nominal/Continuous	100A	
• Peak Discharge (2 min @ 25°C)	125A	
Battery Max. Continuous Charge/Discharge Power (DC)	61.44kW	40.96
ESS Max. Continuous Charge/Discharge Power (AC)	60kW	30kW
Fault Current Contribution per Battery	4,200A / 1.47ms	

Mechanical Specifications

Product Dimensions (WxDxH)	58x58x162 cm (23x23x64 in)	58x58x162 cm (23x23x64 in)
Net Weight	773 kg (1,705lbs)	628 kg (1,384 lbs)
Mounting Type	Freestanding Rack Mount	
Material and Finish	Steel – Powder Coated	
Operating Temperature ³ and Humidity	4°C – 43°C (40°F – 110°F) / 5%–85% RH	
Operating Altitude ⁴	3000m (9,843 ft)	
Storage Conditions ⁵	-4°F – 95°F up to 85% RH (non-condensing) – State of Charge (SOC) 30%	
Ingress Rating	IP20 (NEMA 1)	
Noise Level @ 1m	< 40 dBA at 30°C (86°F)	
Seismic Mounting	Up to Category F	
Communication Ports	CAN2.0/RS485	

Battery Module Specifications

Battery Pack Internal Configuration	12s1p	8s1p
Battery Module Nominal Energy Capacity	5.12kWh	
Battery Module Nominal Voltage and Capacity	51.2V / 100Ah	
Terminal Type	Amphenol SurLok - Push Lock Connector	

Warranty and Certification

Performance Warranty ⁶	10 years or 196MWh Throughput	10 years or 130MWh Throughput
Product Warranty	10 Years	
Certifications	UL1973, UL9540, UL9540a, UN38.3, FCC, Prop 65	

1. DC usable energy, test conditions: 90% DOD, 0.3C charge and discharge at 25°C. System usable energy may vary due to system configuration parameters.

2. Output current is affected by battery temperature and SOC.

3. Temperature is based on the average cell temperature as measured by the BMS. Charging is disabled below 0°C (32°F). Derating occurs above 45°C (113°F). See Sol-Ark technical sales for outdoor sites.

4. Battery will operate at a maximum of 1C charge/discharge up to 2000m, above 2000m maximum output is derated to 0.8C, contact Sol-Ark for details.

5. Storage temperature of the battery with no charge or discharge

6. EOL (End of Life) 70% retained capacity. See L3 Series warranty document for details.

Sol-Ark has a policy of continuous improvement and reserves the right to modify its specifications at any time and without prior notice. Please visit sol-ark.com for the latest information.

2. Installation

System Description

The L3 Series Limitless Lithium™ is a high voltage lithium-ion battery designed for expandable energy storage and reliable backup power. The modular configuration of the L3 allows for expansion through the addition of battery racks. The capacity of the L3 system can be expanded up to 655 kWh and 983 kWh, for the L3 HV-40kWh and L3 HV-60kWh models respectively.

The table below shows the L3 HV models along with their respective capacities, module count, and additional parts:

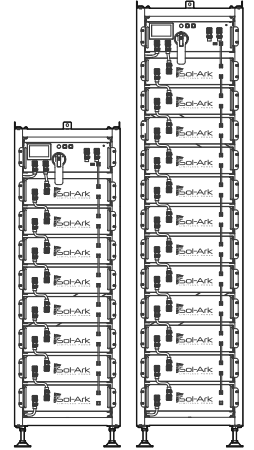

Model	Modules	Total Energy Capacity	Parts
L3 HV-40kWh	8	40.96 kWh	8x L3 HV-5.1kWh + L3 HV BMS-750V
L3 HV-60kWh	12	61.44 kWh	12x L3 HV-5.1kWh + L3 HV BMS-750V

2.1 Part List



NOTICE: The list below outlines the parts and assembly steps specific to the L3 HV-60kWh model. This model is used as reference for system assembly and installation. While the quantity of parts may differ for the L3 HV-40kWh, the assembly steps remain comparable, if not identical.

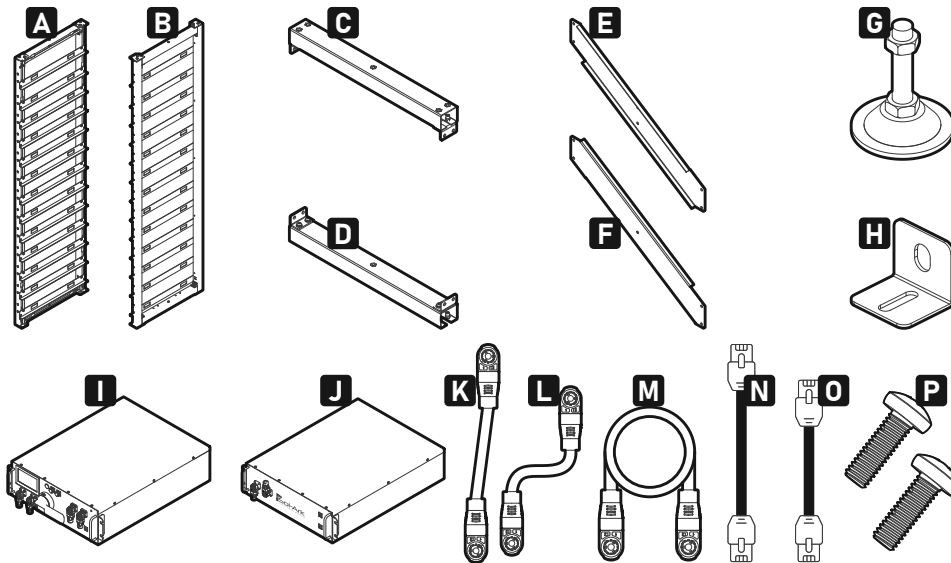

Component	Description	Quantity	
A	Pre-assembled left rack	1	
B	Pre-assembled right rack	1	
C	Top crossbeam	2	
D	Bottom crossbeam	2	
E	Left diagonal brace	1	
F	Right diagonal brace	1	
G	Mounting Feet	4	
H	Rack-to-Wall Angle Bracket (not for seismic installations)	3	
I	Battery Management System Unit (BMS)	1	
J	L3 HV Battery Module	12	
K	Positive Link - Amphenol Battery Cable	1	
L	Series Link - Amphenol Battery Cable	1	
M	Negative Link - Amphenol Battery Cable	11	
N	RJ45 Module-to-Module Communication Cables (140mm)	1	
O	RJ45 BMS-to-Module Communication Cable (110mm)	7	11
P	Battery Rack Screws (M4x20)	90	100

2.2 Assembly

The next steps outline in detail the assembly of the battery rack, the installation of BMS, battery modules and the wiring of the L3 system. Carefully follow each step and verify proper assembly:

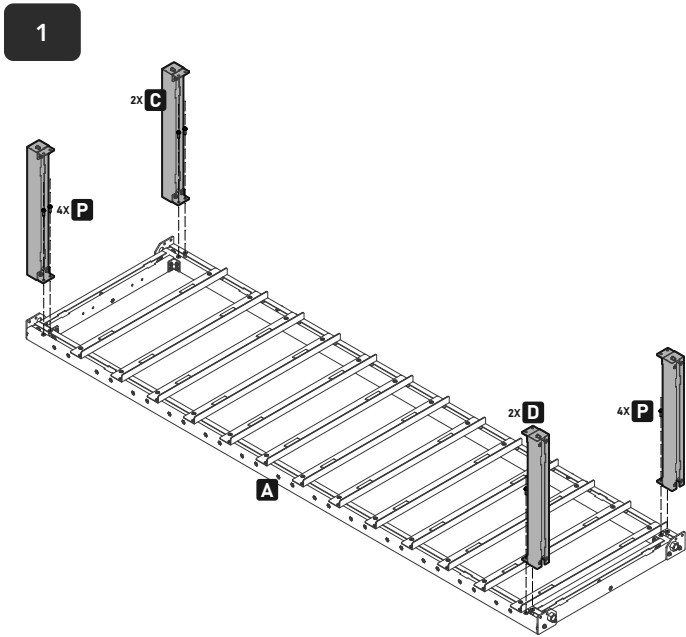

Place the left rack (**A**) on the floor to facilitate assembly. Affix the 2x top crossbeams (**C**) in position and pre-tighten using 4x screws (**P**). Install the two 2x bottom crossbeams (**D**) and pre-tighten using 4x screws (**P**). **!** To easily identify the bottom of the rack, locate the 2x square base plates containing welded nuts.

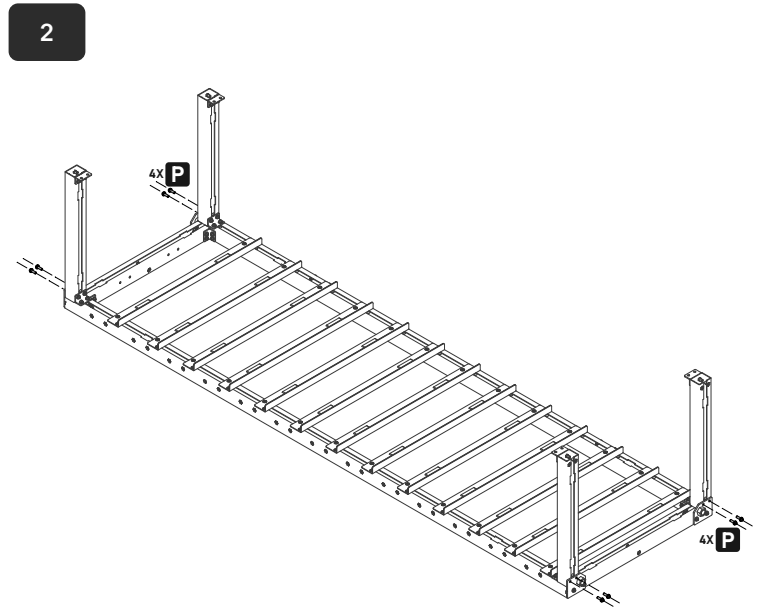

Use 8x additional screws (**P**) to fully secure the crossbeams to the top and the bottom of the rack. Pre-tighten all screws before moving to the next step.

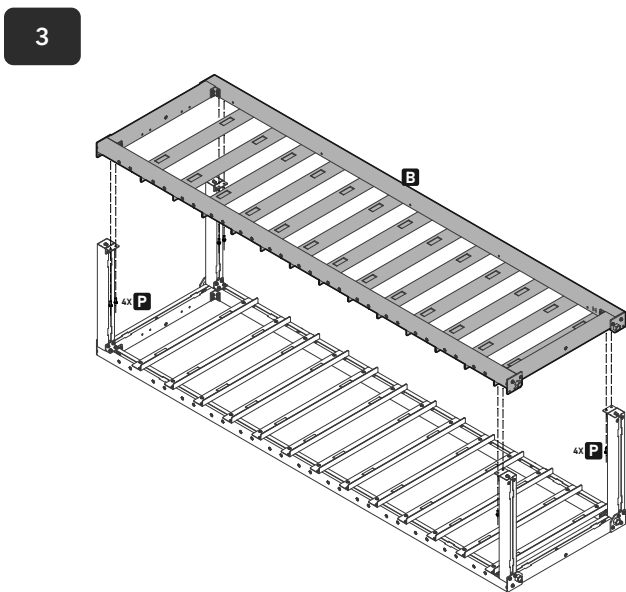

Gently lay the right rack (**B**) onto the previously assembled top and bottom crossbeams, ensuring correct orientation. Align each hole and secure in place with 8x screws (**P**).

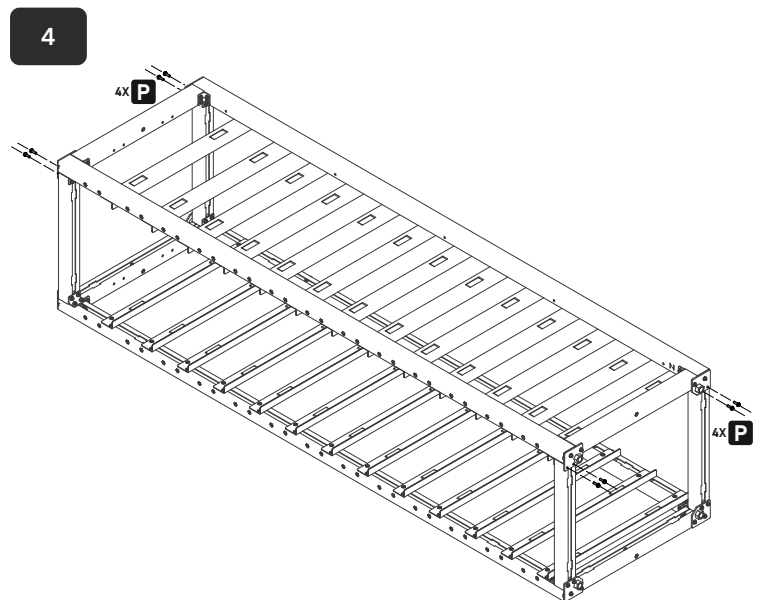

Use 8x additional screws (**P**) to fully secure the right rack to the rest of the assembly. Tighten all screws before moving to the next step.

5

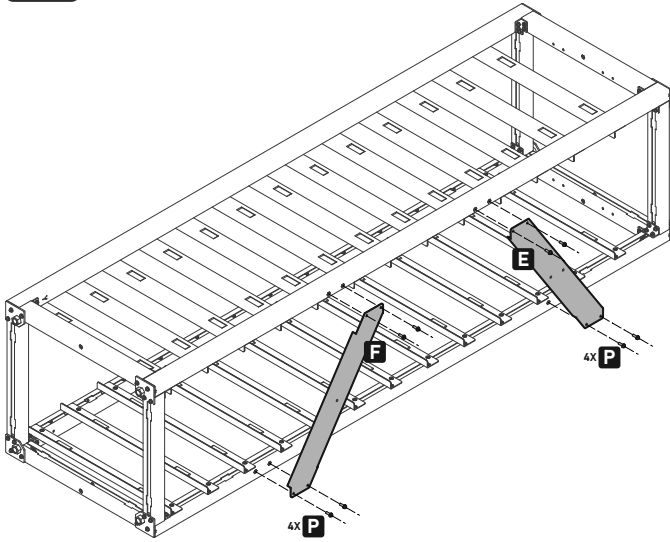

Proceed to the rear of the assembly. Install the left brace (**E**) and right brace (**F**) in their respective holes using 8x screws (**P**). **i** Once installed, please note that the brace flanges will point inwards, towards the rack.

6

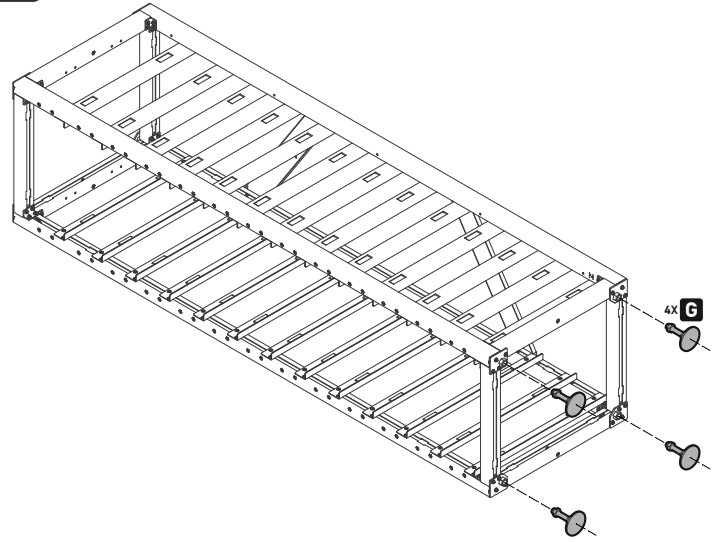

Attach the 4x mounting feet (**G**) to the underside of the rack assembly. Secure the feet by screwing them into the welded nuts of the bottom square base plates.

7

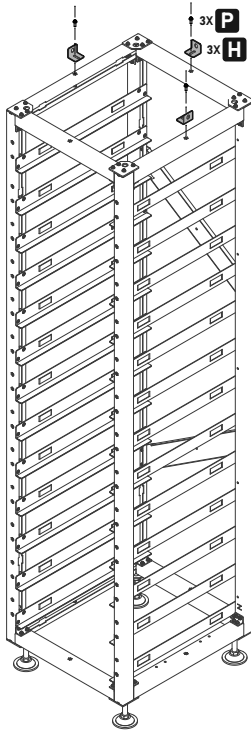

Gently raise the rack into an upright position. If in **non-seismic** area fasten the 3x angle brackets (**H**) using the 3x included screws (**P**) and attach to the wall surface using a suitable fastener for the material.

8

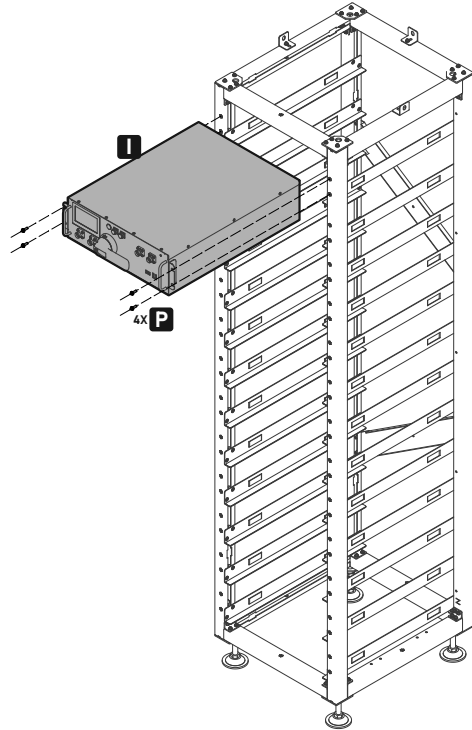

Carefully slide the BMS (**I**) into the top slot of the rack and secure in place using 4x screws (**P**).

9

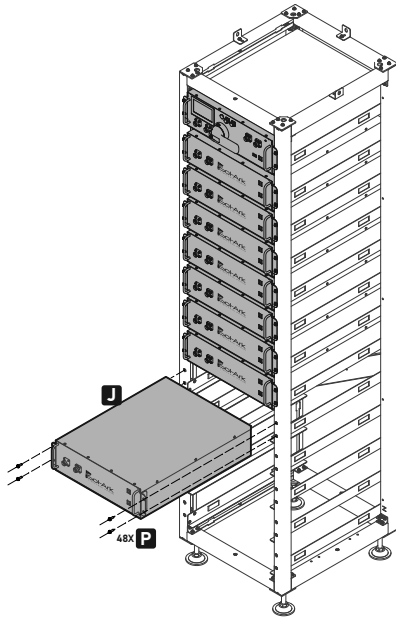

10

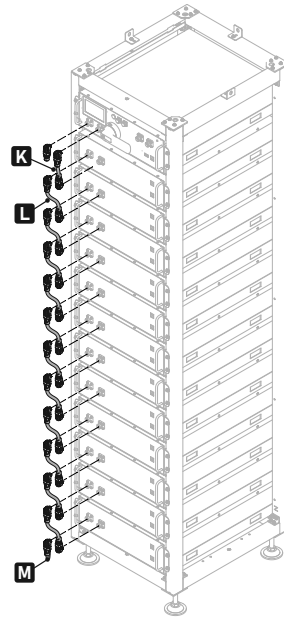

Gradually insert the battery modules (J) one by one into the remaining slots. Ensure proper installation by securing each module with 4x screws (P).

Install the battery module cables (K), (L) and (M) and wire the battery modules appropriately. See section 2.5 for detailed wiring instructions.

11

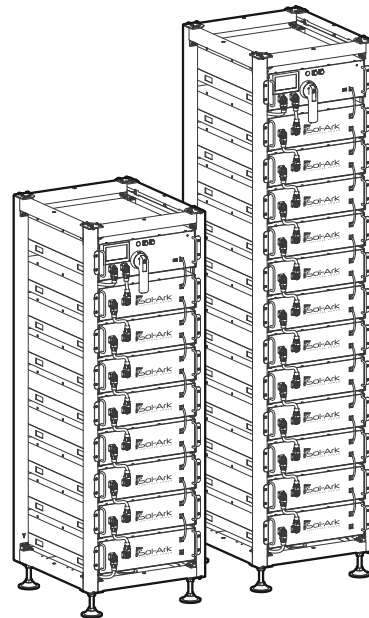
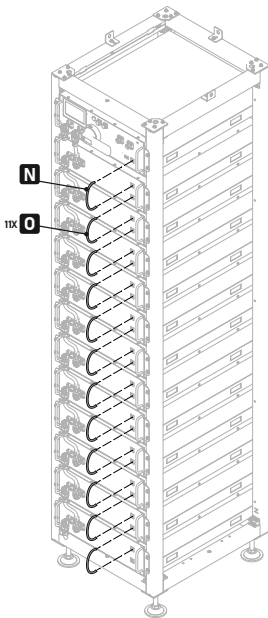

Connect the battery communication cables (M) from module to module as described in section 2.5.

 **WARNING: HEAVY OBJECTS** Damage can occur to the building due to static overload of the floor. Consult with a licensed professional structural engineer when installing batteries above ground level.

2.3 Equipment Clearance Guidelines

The minimum clearances shown below between neighboring systems and surrounding walls are derived from Sol-Ark's UL9540A testing for the L3 HVR series. It's essential to maintain these minimum distances to ensure compliance with the L3 HV UL9540A test report. This is particularly important in areas where adherence to NFPA 855 or similar local fire codes, such as the IFC, is mandatory.

1. Sides/Rear

- Maintain at least **60 cm [23.6 in]** of clearance between the battery sides and any walls or other barriers.
- Maintain at least **10 cm [4 in]** of clearance between adjoining battery racks.
- The rear requires **60 cm [23.6 in]** of clearance between the battery and any walls, barriers, or another battery

2. Front

- **60 cm [23.6 in]** clearance is required in front of the battery racks to be able to open the door or install battery modules.
- Clearance may need to be increased if two batteries have their doors facing each other

3. Ceiling Height

- Install battery racks with a minimum ceiling height of **244 cm [96 in]** measured from the floor. This allows sufficient operator height.
- Ceiling access is not required for this system.

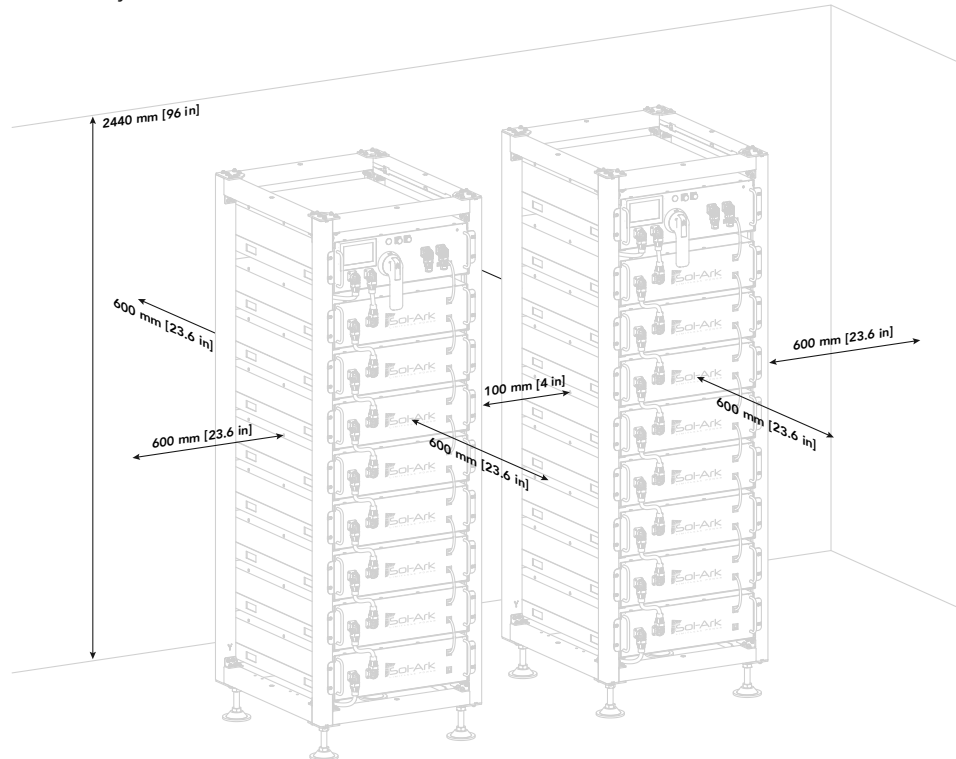

NOTICE: The clearance dimensions listed above are the minimum requirements. Additional clearance may be required by local fire codes or the Authority Having Jurisdiction (AHJ).

2.4 Seismic Installation Guidelines

When installing the L3 system, it is important to follow all bracing requirements to ensure structural integrity during a seismic event. Specific installation methods will depend on the requirements of your local AHJ, but the following general guidelines apply:

- Do not fasten the battery directly to drywall or using expanding anchors. The Sol-Ark supplied mounting brackets must be secured to wall studs or other structural building elements.
- If installing on a raised floor, consult a licensed structural engineer to ensure the raised floor is rated for the weight and forces of the battery system for your seismic zone.



NOTICE: For information on pre-engineered stamped designs for use in Category E seismic areas and above please reach out to Sol-Ark at: support@sol-ark.com or +1 (972) 575-8875, Ex. 2.

After completing the L3 assembly, the total weight of the battery energy storage system is 628 kg (1,384 lb) or 773 kg (1,705 lb) for the L3 HV-40kWh and L3 HV-60kWh models respectively. Ensure that the installation site has sufficient bearing capacity to support the weight of the number of batteries installed.

2.5 Battery Overview

1. BMU

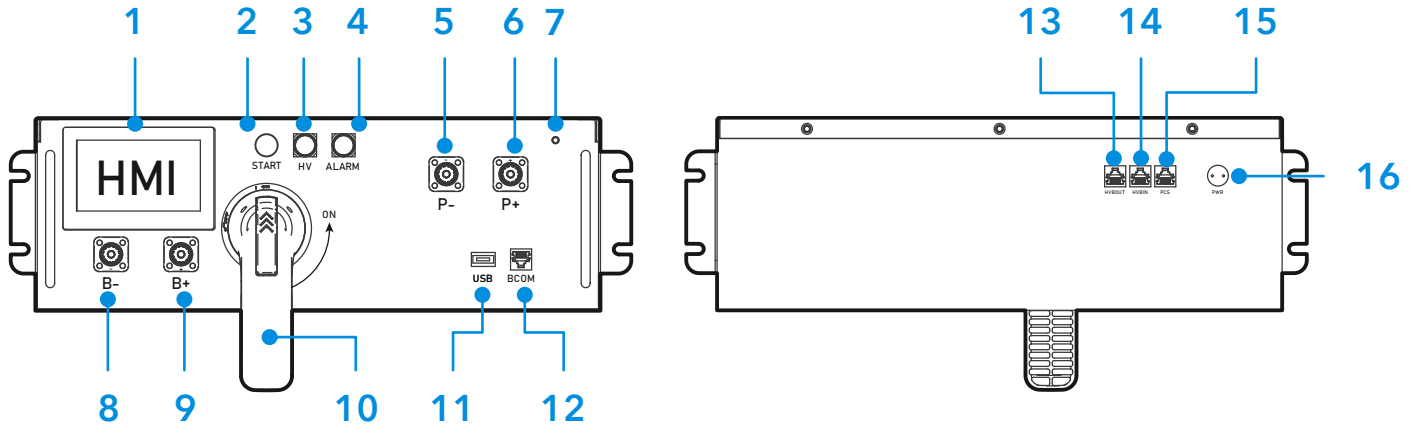

No.	Name	Description
1	Touchscreen HMI	Touchscreen Display for Battery Diagnostics and Settings Configuration
2	START	BMS Power Button
3	HV Indicator	High Voltage Present Indicator (yellow).
4	ALARM indicator	System Fault Indicator (red).
5	PCS-	Negative (-) – PushLok Connector to Inverter Input
6	PCS+	Positive (+) – PushLok Connector to Inverter Input
7	Grounding Terminal	Ground Point Between the Battery Rack and Module.
8	B-	Negative (-) – Module PushLok Connector.
9	B+	Positive (+) – Module PushLok Connector.
10	DC Disconnect	200A Dual Pole DC disconnect for the battery output (P+/P-).
11	USB	USB2.0 port for data logging or firmware updates
12	BCOM	Inter-battery communication port for the first battery module [INPUT/OUTPUT]
13	HVBOU	Communication output port to next L3 HV BMS. [OUTPUT]
14	HVBIN	Communication input port for previous L3 HV BMS [INPUT]
15	PCS	RJ45 port for BMS to Inverter closed-loop communication [OUTPUT]
16	PWR	Input for External 12V Power (for over-discharge recovery). [INPUT]

2. Battery Module



No.	Name	Description
1	B-	Negative (-) Amphenol battery module connector.
2	B+	Positive (-) Amphenol battery module connector.
3	BCOM IN	Communication port for previous battery module
4	BCOM OUT	Communication port to next battery module

2.5 Wiring



WARNING: Before wiring the system, ensure the DC disconnect switch of the BMS is turned OFF and the MSD is disconnected



DANGER: RISK OF DAMAGE. Battery modules provide power via BCOM IN and BCOM OUT ports. **DO NOT** connect PCS communications to either of these ports.

1. High-Voltage DC Wiring

- Verify a secure installation of the BMU and battery modules onto the rack by following steps 9 and 11 of the assembly instructions. Refer to section 2.2 for more comprehensive details on how to assemble the battery rack.
- Install the 220 mm battery conductor from the positive Amphenol battery connector (**B+**) of the BMU to the positive Amphenol battery connector (**B+**) of the first battery module.
- Install the 200 mm battery conductors from module to module. Ensure connection in series from the negative Amphenol battery connector (**B-**) of the first battery module to positive Amphenol battery connector (**B+**) of the subsequent battery module.

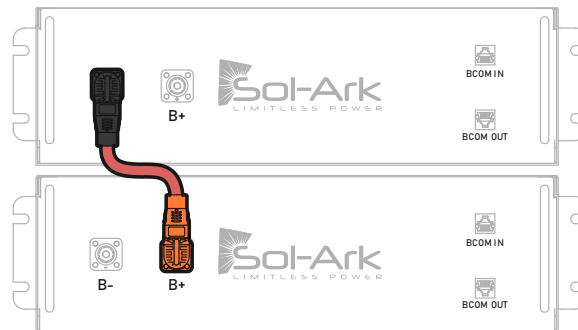

Figure 1: Inter-Module Series Jumpers

- Connect the remaining battery conductors in the manner.
- Install a long battery conductor from the last battery module to the BMU. This is done by linking the negative Amphenol battery connector (**B-**) of the last module to the remaining unconnected negative Amphenol battery connector (**B-**) of the BMU.

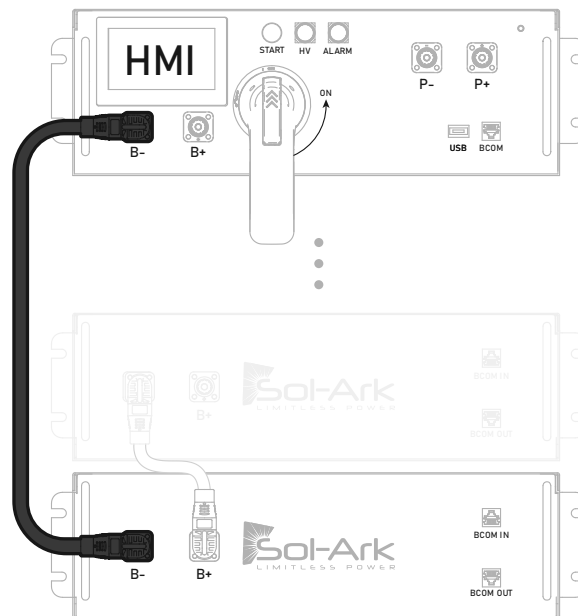

Figure 2: Main Negative Jumper

- Connect the grounding wire from the BMU to any available hole in the top crossbeam of the battery rack. Safely fasten it in position using M4 and M6 screws, respectively.
- Connect a grounding wire from the marked holes in the bottom crossbeam of the battery rack to the sites grounding system.
- To interconnect an inverter, use the included Amphenol connectors. Run the wires from the positive and negative Amphenol connector (**P+**) and (**P-**) to the inverter's battery input terminals, as shown in Fig 3.

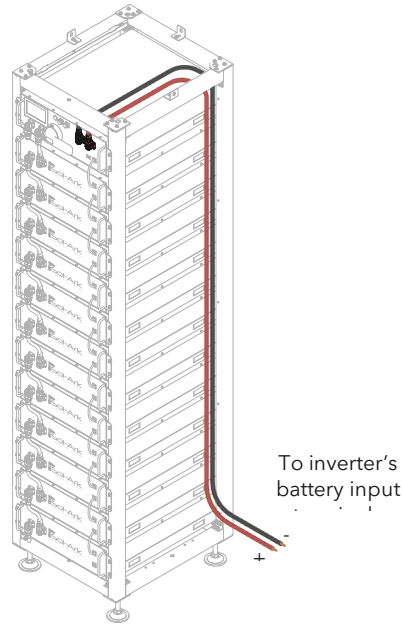

Figure 3: Battery to Inverter Wiring

2. Communications Wiring

- After all battery modules are installed, locate the included 140mm (5.5in) BMU communication cable. Connect one end to the **BCOM** communication port of the BMU. Subsequently, connect the other end to the **BCOM IN** communication port of the first module.

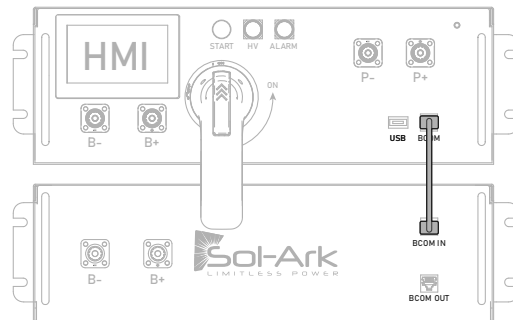

Figure 4: Inter-Module Communication Jumpers

- Locate 7 pieces (or 11 pieces) of the 110mm (4.3in) inter-battery communication cables that connect the battery modules together.
- Connect one end to the **BCOM OUT** communication port of the first battery module. Connect the other end to the **BCOM IN** communication port of the subsequent battery module.
- Connect all remaining 110mm (4.3in) communication cables for the rest of the battery modules.

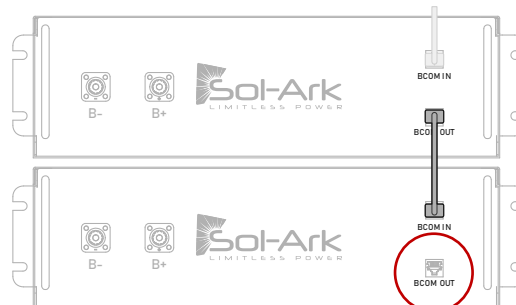

Figure 5: Terminating Resistor



NOTICE: The BCOM OUT port of the last battery module should be terminated with the included 120Ω terminating resistor plug.

2.6 Battery Communications

The L3 Series Limitless Lithium™ energy storage system employs a CAN (Controller Area Network) communication system to communicate among battery modules and daisy-chained BMUs of paralleled L3 stacks, up to 16 units. For PCS (Power Control System) devices like Sol-Ark hybrid inverters the battery can communicate via either CAN or RS485 MODBUS.



NOTICE: Only the 30K-3P-208V and 60K-3P-480V inverters are supported by the L3 Limitless Lithium™ series. In addition, only CAN based battery to inverter communication is supported.

Battery communications is essential for correct operation and optimal performance. The following figures and tables provide a detailed overview of the pin configuration of the different communication ports within the L3 system.

BMU (FRONT)

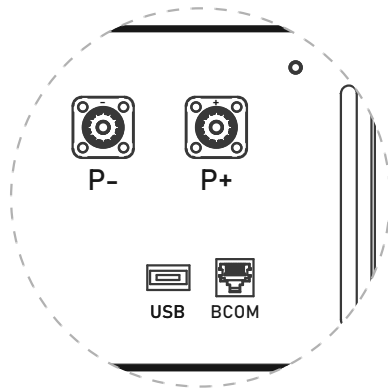

BATT MODULE (FRONT)

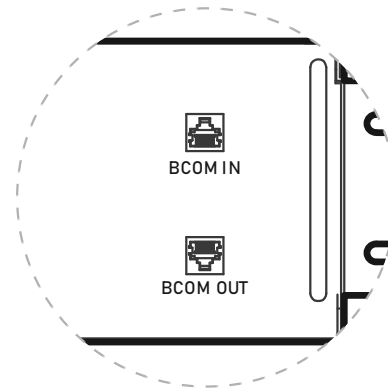

Pin	BMU
--	BCOM
1	BMU_CANL
2	BMU_CANH
3	DO+
4	DO-
5	GND
6	GND
7	12V
8	12V

Battery Module	
BCOM IN	BCOM OUT
BMU_CANL	BMU_CANL
BMU_CANH	BMU_CANH
DI+	DO+
DI-	DO-
GND	GND
GND	GND
12V	12V
12V	12V

BMU (BACK)

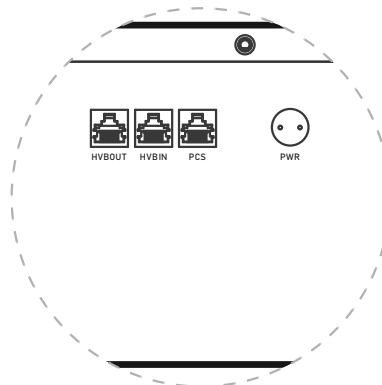

Pin	HV OUT
1	BMS_CANL
2	BMS_CANH
3	DI+
4	DI-
5	--
6	--
7	--
8	--

Pin	HV IN
1	BMS_CANL
2	BMS_CANH
3	DI+
4	DI-
5	--
6	--
7	--
8	--

Pin	PCS
1	485B-
2	485A+
3	--
4	PCANH
5	PCANL
6	--
7	485A+
8	485B-

2.7 Powering-up the Sol-Ark L3 System



CAUTION: Follow proper safety measures including lock-out tag-out and wearing any OSHA required PPE when powering-up and testing the system.

1. Verify Battery Module Voltage

- The nominal voltage of 5.1kWh battery module is 51.2V, any voltage within a range of 50V to 56V is considered normal.
- Using a digital multimeter verify proper DC voltage between the B+ and B- connectors of the first battery module.
- Repeat the measurement across **ALL** battery modules to confirm consistent voltage levels.
- DO NOT** commission a pack with a module-to-module voltage delta (between the highest and lowest) of more the **0.2Vdc**
 - If you have a module delta above 0.2V contact Sol-Ark support for next steps.
- Once all battery modules have been verified to be within 0.2Vdc, use a digital multimeter measure and verify you get the correct **pack level voltage** between the B- connector of the first battery module and B- connector of the last battery module.
 - This voltage is calculated according to the following equation: $V_{\text{pack}} = N_{\text{series}} \times V_{\text{module}}$
 - For a 60K configuration this should be between 600-672Vdc
 - For a 30K configuration this should be between 300-336Vdc
- Re-attach the cables and ensure all Pushlok connectors are properly seated.

2. Turning On the L3 system

- Twist the handle clockwise to the **ON** position, the DC disconnect switch will click and latch in place.
- NOTE:** The DC disconnect features a built-in locking tab that can be used to lock out the disconnect in the **OFF** position for service and maintenance.

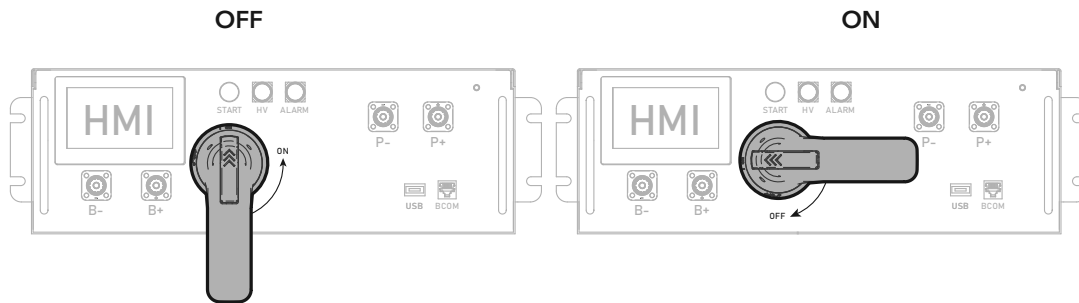

- PRESS** the START button of the BMU to the **ON** position. The Sol-Ark boot-up screen will appear.

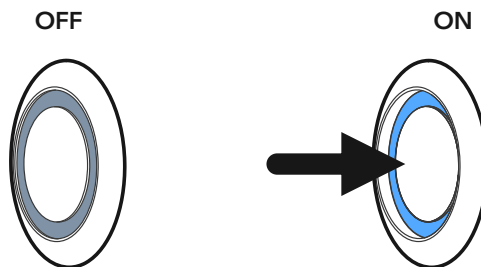

- The **high voltage "HV"** indicator will light up.
- Wait a few seconds, then tap the screen once to access the home screen.

2.8 Power Cycle Sequence

- PRESS** the START button, making sure it is in the OFF position.
- TURN OFF** the DC disconnect switch. The LCD screen will turn off.
- Wait a moment (~1 min) to ensure the inverter is completely de-energized.
- Ensure the "HV" light indicator is **OFF**.
- Ensure proper connectivity among **ALL** battery modules, BMU, and integrated inverter within the L3 system.
- Follow the sequence in Section 2 to turn **ON** the L3 system.

3. User Interface

3.1 HMI Screens

1. Home Screen

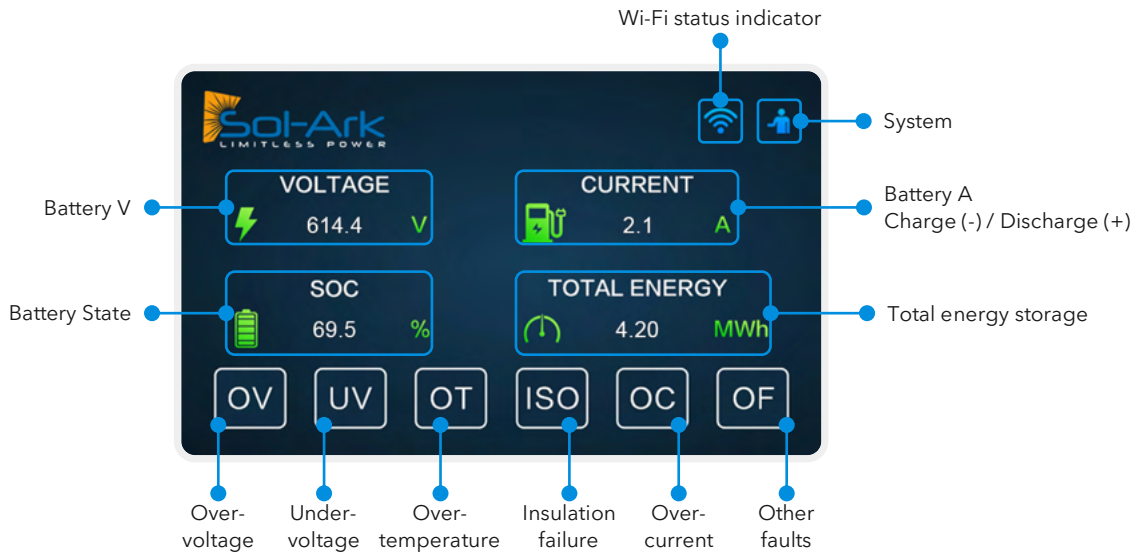

2. Login Screen

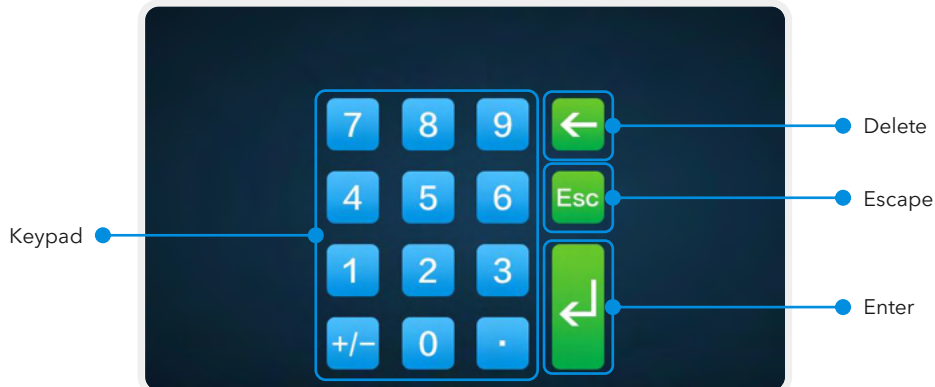

3. System Maintenance Screen

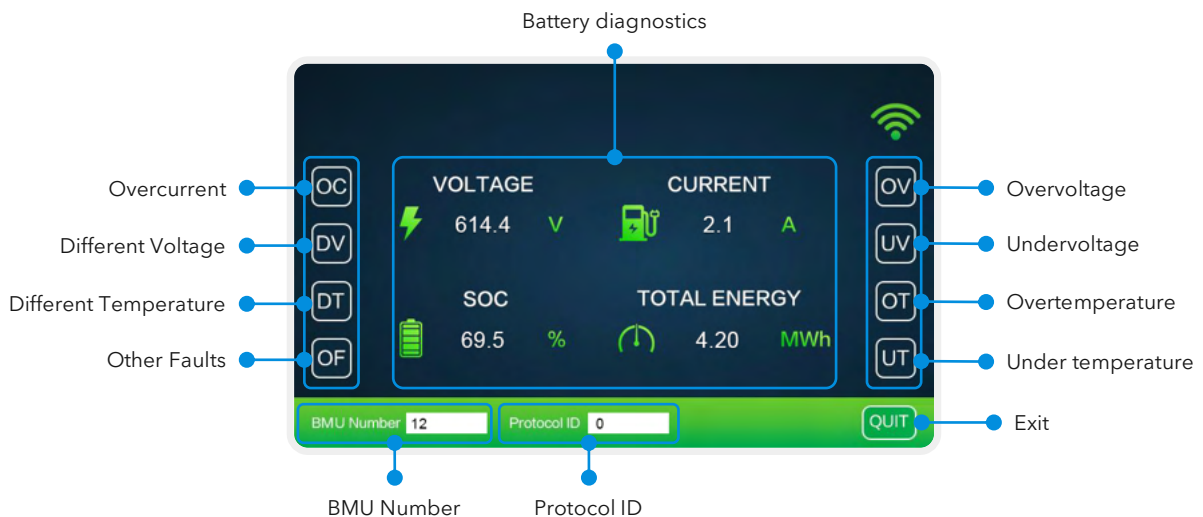

3.2 System Setup

Battery communication of the L3 Series Limitless Lithium™ system will automatically setup the system and identify the number of battery modules detected on the CAN bus. To enter the system maintenance and configuration screen to confirm these values or to access more detailed descriptions about the faults, perform the following steps.



1. Tap the center of the screen to access the home screen menu.

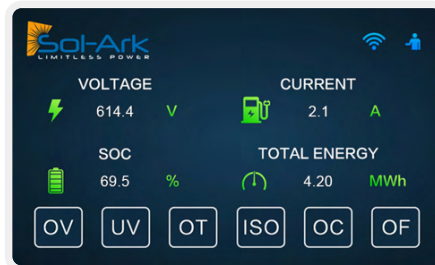

2. At the top-right corner of the screen, tap the icon to access the system maintenance menu. A security screen will appear and request a passcode.

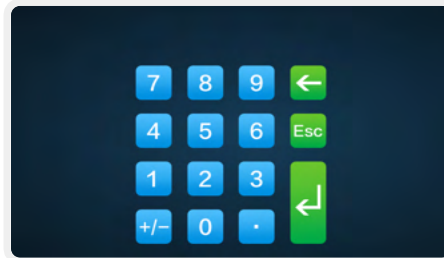

3. Enter the code **1 2 3** by tapping the numbers on the screen. Press the button to enter the code and proceed to the system setup menu.

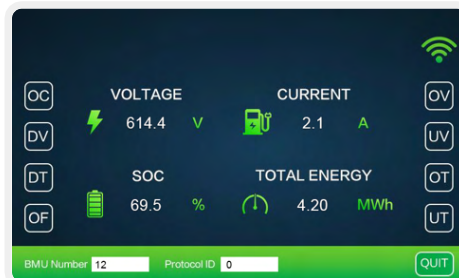

4. The "BMU Number," located at the bottom-left of the screen, serves to identify the quantity of battery modules within the L3 system. This number is automatically displayed when there is proper communication between the battery modules and the BMU.
5. The "Protocol ID" defines the CANBus communication protocol utilized by the L3 system. ID 0 should be selected for Sol-Ark Inverters
6. You can tap on each Fault icon positioned on the right and left sides of the screen to access additional information about faults, including detailed descriptions and common causes.



NOTICE: In the event of a fault, the "Alarm" indicator on the BMU will illuminate, and the corresponding fault will be highlighted in red on both the "Home Screen" and the "System Maintenance Screen". You can access the "Maintenance Screen" and tap on the respective fault for more info.

4. Operation and Maintenance

4.1 Maintenance of the L3 system



CAUTION: Follow proper safety measures including lock-out tag-out and wearing any OSHA required PPE when powering-up and testing the system

For safe operation, it is essential to thoroughly inspect all components of the L3 system, including but not limited to system conductors, connectors, wiring between modules, BMU and ground. The following annual maintenance tasks and inspections should be carried out by a qualified professional:

1. Perform a basic visual inspection of the system.
2. Verify the tightness of all electrical connections, including any torque values described in section 1.2.
3. Keep the unit clean and free of any dust and debris.



NOTICE: To clean the battery rack, BMU, or modules, use a damp cloth to wipe down any surfaces, no harsh solvents or cleaning products should be used. Ensure that the battery connections remain free from any moisture.

4.2 Fire Suppression System

The L3 HV series features an integrated aerosol-based fire suppression system at the battery module level. In the rare event of a thermal runaway, the aerosol canister would rapidly deploy, filling the battery module interior with non-toxic agent to suppress any potential fire before spreading. This unique, industry-leading safety capability from Sol-Ark ensures maximum protection for commercial and industrial users.

Module Level: Contained in each module is a 12-gram aerosol agent canister, this proprietary system activates automatically when heat inside the module reaches potentially unsafe levels due to thermal runaway or external fires ($185^{\circ}\text{C} \pm 10^{\circ}\text{C}$).

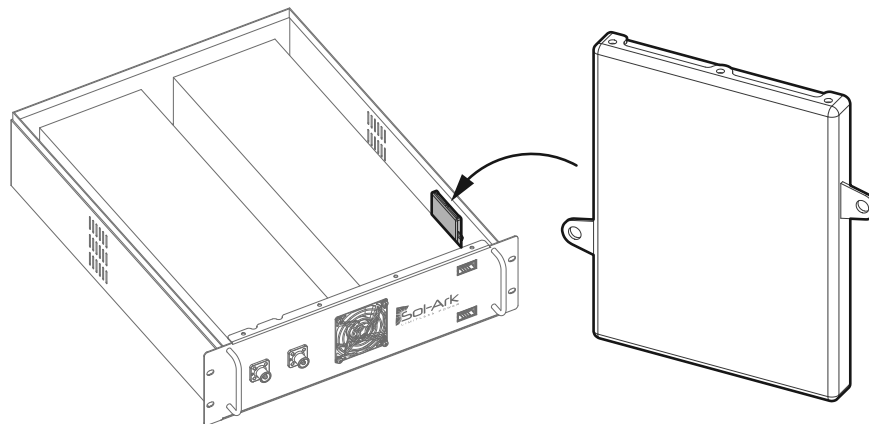

Figure 6: Module level aerosol agent canister

4.3 Over-Discharge Recovery

The Battery Management Unit (BMU) is designed to receive power directly from the battery stack. If the battery is left without a charging source for an extended amount of time, the BMU and other system devices standby power consumption could lead to an over-discharge of the batteries below the required input voltage for BMU operation.

In such instances, it may become necessary to restore power to the BMU by utilizing the provided external 12V power supply cord. This process involves using the input connector located on the back of the BMU. Connecting a 12V supply to the **"PWR"** input of the BMU using the included two-wire connector. Doing so will enable the BMU to power on and close the contactors, allowing the batteries to be recharged.

4.4 HMI Firmware Update Process



CAUTION: Prior to opening the battery module, please contact us at: support@sol-ark.com or +1 (972) 575-8875, Ex. 2

1. ⚠️ Ensure the DC disconnect is turned **OFF** before doing any maintenance.
2. ⚠️ Unplug the **ALL** four B+, B-, P+ and P- conductors from the BMU and wait at least **5 minutes** before opening unit.
3. Remove the top metal cover of the BMU by unscrewing all x13 M4 screws as shown below.

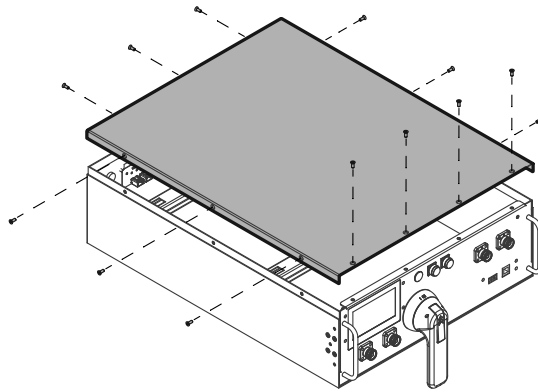

4. Locate the SD card slot.

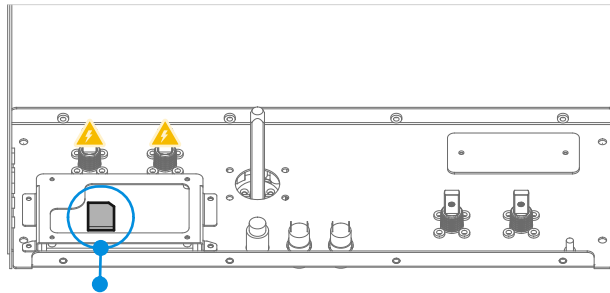

SD Card Slot

4.5 BMS Firmware Update Process

1. The USB port of the BMS allows for upgrading firmware and logging battery data.
2. To update the firmware first format a USB 2.0 drive as **FAT32**, no larger than **8GB** in size.
3. In the root directory of the USB drive create new folder called "upgrade", all lowercase.
4. Place the .bin file provided by Sol-Ark in the "upgrade" folder on the USB drive.
5. Turn on the battery following the procedure outlined in **Section 2.7**.
6. Insert the USB drive once the battery has completely turned on.
7. Within 5s of inserting the USB drive the blue light around the Start button will blink during the update process.
8. Once this light turns off, remove the USB drive to complete the upgrade. Do not power off the battery during the process using the Start button or DC disconnect.
9. After the blue light around the Start button lights up again the update should be complete.
10. Verify the version number using the version number displayed on the inverter under the Lithium Battery Info screen or via the BMS diagnostic software.

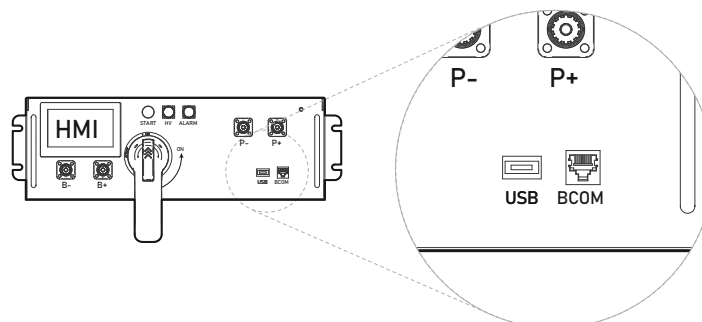

4.5 Long Term Battery Storage

When storing the assembled battery system for periods longer than 1 week it is recommended that the following steps be performed.

- To maximize battery lifespan, maintain storage temperature between 13°C – 30°C (55°F – 86°F).
- Power on and cycle the battery at least once every 6 months to maintain the SOC within 30-50%.
- Minimize BMU self-discharge by disconnecting the negative Amphenol battery connector (**B-**) during this period. This interrupts the power supply to the BMU, preventing battery discharge.

4.7 Wiring Diagrams

CAUTION: These diagrams are illustrative and not exhaustive. They may not cover all variations required by local codes and should not be solely relied upon for permitting or warranty purposes. Consult relevant authorities and ensure full compliance before installation. Installers should exercise caution, seek professional advice when necessary, and adhere to established electrical standards and regulations during all installations.

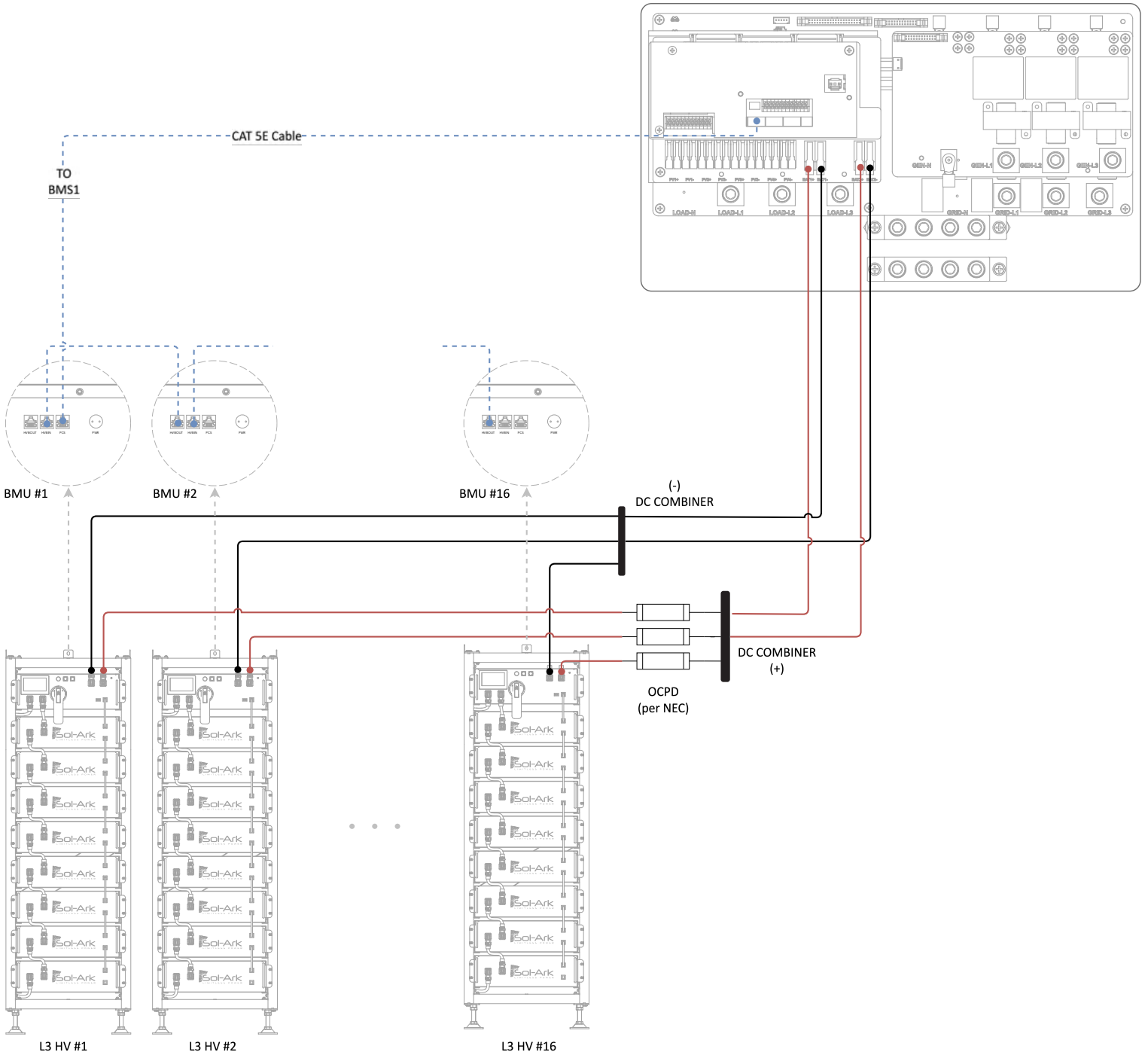

Figure 7: Multi-Stack Battery Wiring

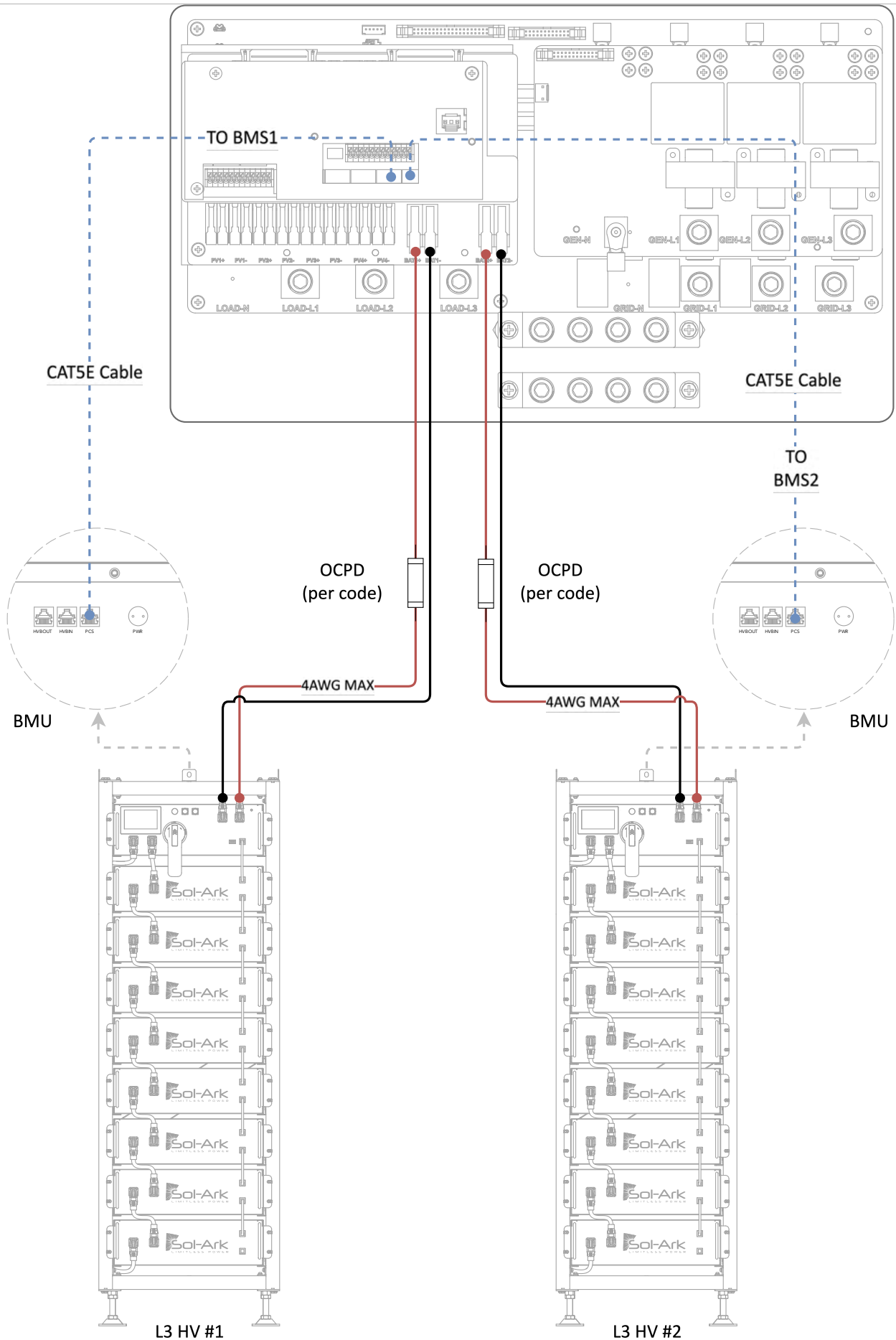

Figure 8: Two Battery System Connections

5. Error Codes

5.1 Description of System Faults



NOTE: For more information, please contact us at: support@sol-ark.com or +1 (972) 575-8875, Ex. 2

Fault	Potential Fault Cause
OT (Over Temperature)	BMS Positive connector overtemperature
	BMS Negative connector overtemperature
	Pre-charge resistor overtemperature level-2 alarm
	Heating film overtemperature level-2 alarm
	Charge overtemperature level-2 alarm
	Discharge overtemperature level-2 alarm
UT (Under Temperature)	Charge under temperature level-2 alarm
	Discharge under temperature level-2 alarm
OC (Over Current)	Charge overcurrent level-2 alarm
	Discharge overcurrent level-2 alarm
DV (Differential Voltage)	Excessive differential voltage level-2 alarm
DT (Differential Temperature)	Excessive differential temperature level-2 alarm
OV (Over Voltage)	Total charge voltage too high
	Cell overvoltage level 2 alarm
UV (Under Voltage)	Charge voltage too low
	Total discharge voltage too low
	Cell undervoltage level-2 alarm
OF (Other Fault)	Abnormal numbers of BMU
	BMU lost
	RTC clock fault
	Current module fault
	SCHG total voltage acquisition fault
	Abnormal RS485 communication
	RS485 communication failure
	Inverter CAN communication failure
	Repeated BMS Address fault
	Repeated BMU Address fault
	Abnormal power supply voltage
	Heating relay Welded
	SOC low
	SOC high
	Internal Fuse Blown
	Charge Relay Welded
	Discharge Relay Welded
	Master Positive Relay Welded
	Temperature Acquisition Failure
	Cell voltage acquisition fault
	Inter-battery communication failure
	Pre-charge failure
	Insulation level 2 alarm
	External total voltage acquisition fault
	Internal total voltage acquisition fault
	Current acquisition fault
Limit protection	
EEPROM failure	
ISO	Insulation level 2

5.2 Common Causes

FAULT TYPE	COMMON CAUSES
Charge over-current alarm	More than 105A for 2s; more than 125A for 5s; or more than 140A for 2s;
Charge over-current protection	If the battery is operating below 5°C (41°F) then:
Discharge over-current alarm	52.5A for 2s; more than 62.5A for 5s; or more than 70A for 2s;
Discharge over-current protection	
Charge overtemperature alarm	Exceeding the parameter set value and set time (>45°C, 2s)
Charge overtemperature protection	Exceeding the parameter set value and set time (>50°C, 2s)
Discharge overtemperature alarm	Exceeding the parameter set value and set time (>50°C, 2s)
Discharge overtemperature protection	Exceeding the parameter set value and set time (>55°C, 2s)
Charge under temperature alarm	Exceeding the parameter set value and set time (<5°C, 2s)
Charge under temperature protection	Exceeding the parameter set value and set time (<0°C, 2s)
Discharge under temperature alarm	Exceeding the parameter set value and set time (<-10°C, 2s)
Discharge under temperature protection	Exceeding the parameter set value and set time (<-20°C, 2s)
Excessive differential voltage alarm	Exceeding the parameter set value and set time (>500mv, 2s)
Excessive differential voltage protection	Exceeding the parameter set value and set time (>800mv, 2s)
Excessive differential temperature alarm	Exceeding the parameter set value and set time (>10°C, 2s)
Excessive differential temperature protection	Exceeding the parameter set value and set time (>15°C, 2s)
Cell overvoltage alarm	
Cell overvoltage protection	To maintain consistency, cut off the charging immediately when the full charge calibration rated voltage of 3.6V is reached. When the voltage drops to 3.35V, restart it with the turned-off red light indicator. All protective red light indicators are always on!
Cell undervoltage alarm	
Cell undervoltage protection	
Pre-charge resistor overtemperature alarm	Exceeding the parameter set value and set time (>55°C, 2s)
Pre-charge resistor overtemperature protection	Exceeding the parameter set value and set time (>65°C, 2s)
Insulation level 1	Exceeding the parameter set value and set time
Insulation level 2	Exceeding the parameter set value and set time
Heating film overtemperature alarm	Exceeding the parameter set value and set time (>75°C, 2s)
Heating film overtemperature protection	Exceeding the parameter set value and set time (>80°C, 2s)
BMS connector overtemperature alarm	Exceeding the parameter set value and set time
BMS connector overtemperature protection	Exceeding the parameter set value and set time
BMU connector overtemperature alarm	Exceeding the parameter set value and set time
BMU connector overtemperature protection	Exceeding the parameter set value and set time
Power loop overtemperature alarm	Exceeding the parameter set value and set time
Power loop overtemperature protection	Exceeding the parameter set value and set time
SOC too low	Exceeding the parameter set value and set time
Total voltage too high alarm	Exceeding the parameter set value and set time
Total voltage too high protection	Exceeding the parameter set value and set time
Total voltage too low alarm	Exceeding the parameter set value and set time
Total voltage too low protection	Exceeding the parameter set value and set time
Discharge relay adhesion	Relay feedback information state welded
Charge Relay Welded	Relay feedback information state welded
Heating Relay Welded	High voltage is detected after disconnecting the heating relay
Limit protection	Exceeding the parameter set value and set time
Abnormal power supply voltage	Exceeding the parameter set value and set time
Master positive Relay Welded	Relay feedback information state adhesion
Fuse Blown	No high voltage is detected after the relay is closed
Repeated BMU address fault	BMU with the same number
INTER-CAN BUS communication failure	Loss of communication between BMS
PCS-CAN BUS communication failure	The heartbeat message of the inverter has been not received for a long time
RS485 communication failure	Inverter RS485 access is not received for a long time
Abnormal RS485 communication	C
External total voltage acquisition fault	/
Internal total voltage acquisition fault	The difference between the acquired internal total voltage and the accumulated internal total voltage exceeding the set value
SCHG total voltage acquisition fault	/
Cell voltage acquisition fault	The cell voltage acquired is 0
Temperature acquisition failure	The temperature acquired is -40°C
Current acquisition fault	/
Current module fault	Abnormal Hall Effect current sensor voltage
EEPROM storage failure	EEPROM write failure during self-test
RTC clock fault	The external RTC failed to enable the charging function
Pre-charge failure	Battery Pre-charge timeout
Charging voltage too low	The minimum cell voltage is lower than the set value
BMU lost	BMU message not received for a long time
Abnormal number of BMU	The number of BMU addresses is different from the number of set parameters