

K2 Multi Mount, Kit

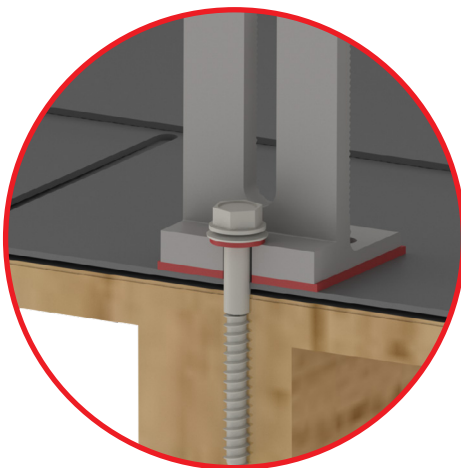

DATA SHEET

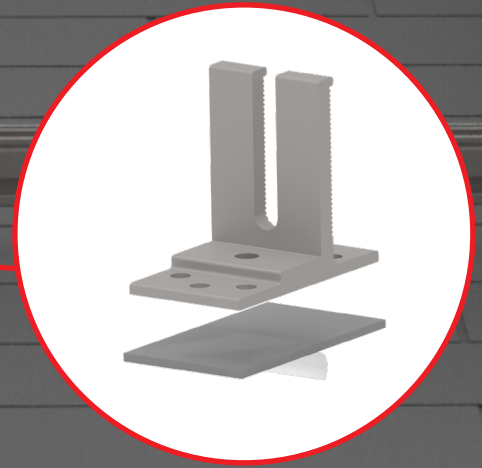
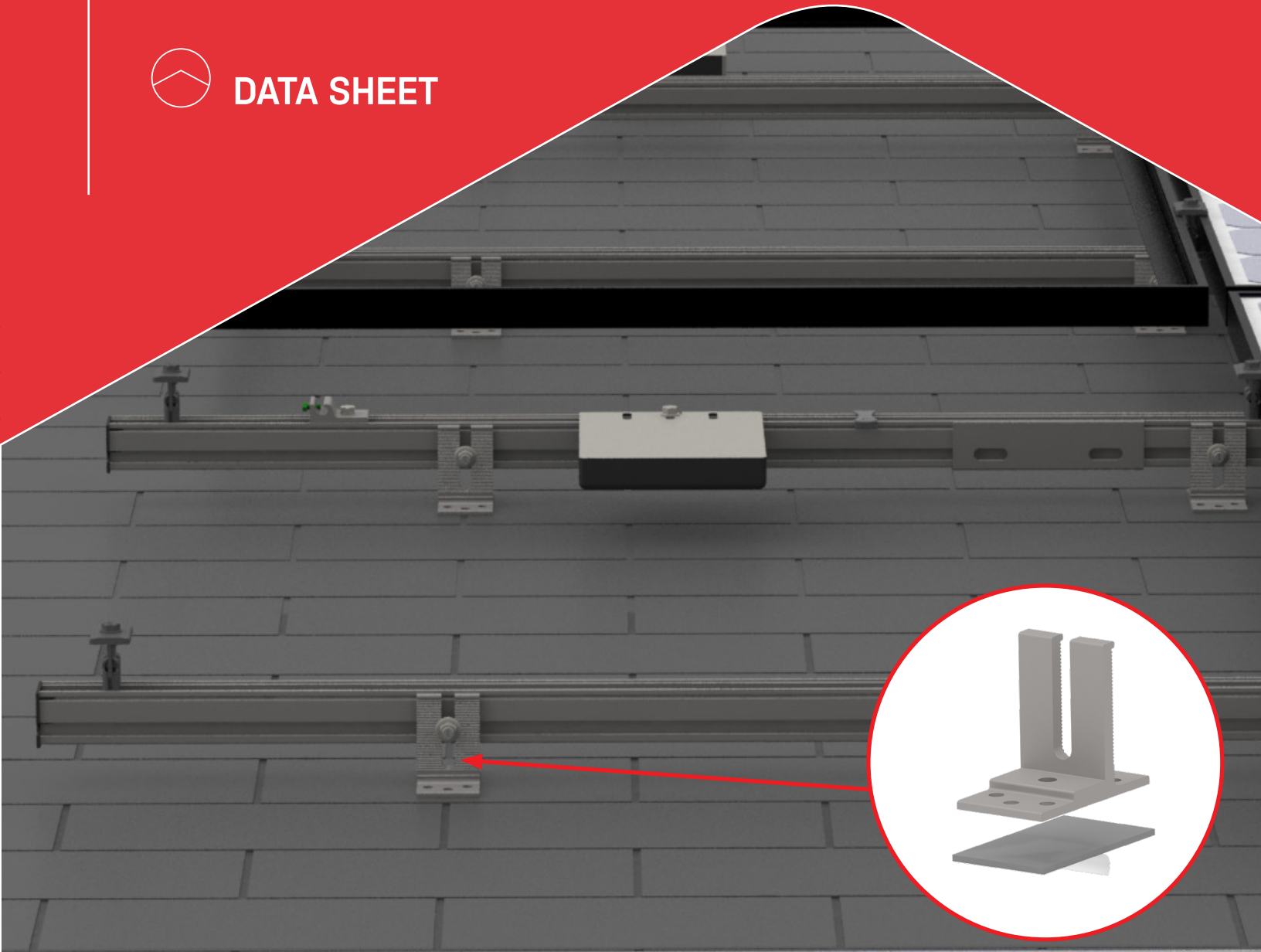

K2 Multi Mount, Kit
/ Rafter attachment with 1 lag bolt
/ Decking attachment with 4 screws

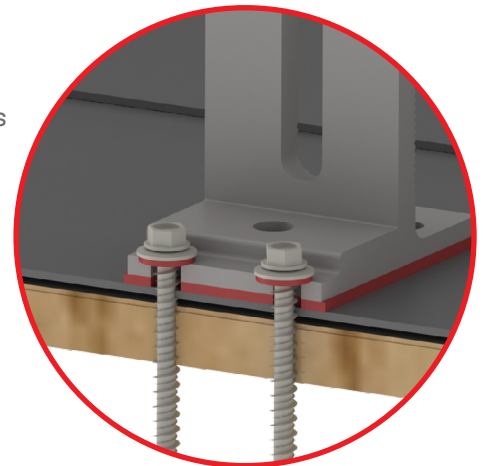

PRODUCT FEATURES

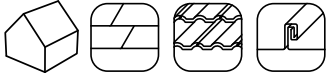

- / Pre-assembled with K2 EverSeal
- / Open slot design for rapid install to rail components with retention lip
- / Proven pullout value of **320lbs** for deck
- / Proven pullout value for lag screw of **1065lbs** for rafter
- / Optimized for 4in of clearance off the roofs surfaces

TECHNICAL DATA

K2 Multi Mount, Kit	
Part Number(s)	4000282 (mill), 4000284 (dark)
Application	3-45 degree parallel/flush attached and tilt up
Roof Type	Composition shingle, EPDM, TPO, Bitumen, Asphalt, Concrete and Metal
Material	Aluminum
Finish	Mill or Dark
Module Orientation	Portrait and landscape
Structural Validity	ASTM D7147, SEAOC 2, Based on ASCE 7-16
Certifications	UL 441 Section 27, Raining Test, TAS 100(A) -95
Warranty	25 years
Roof Connection Options	
Rafter 2 Screws	(2) #14 × 3" x 5/16" Hex Head Screw
Rafter Single Lag	(1) 5/16" lag screw to rafter
Deck 4 Screws	(4) #14 × 3" x 5/16" Hex Head Screw

Units: mm [in]

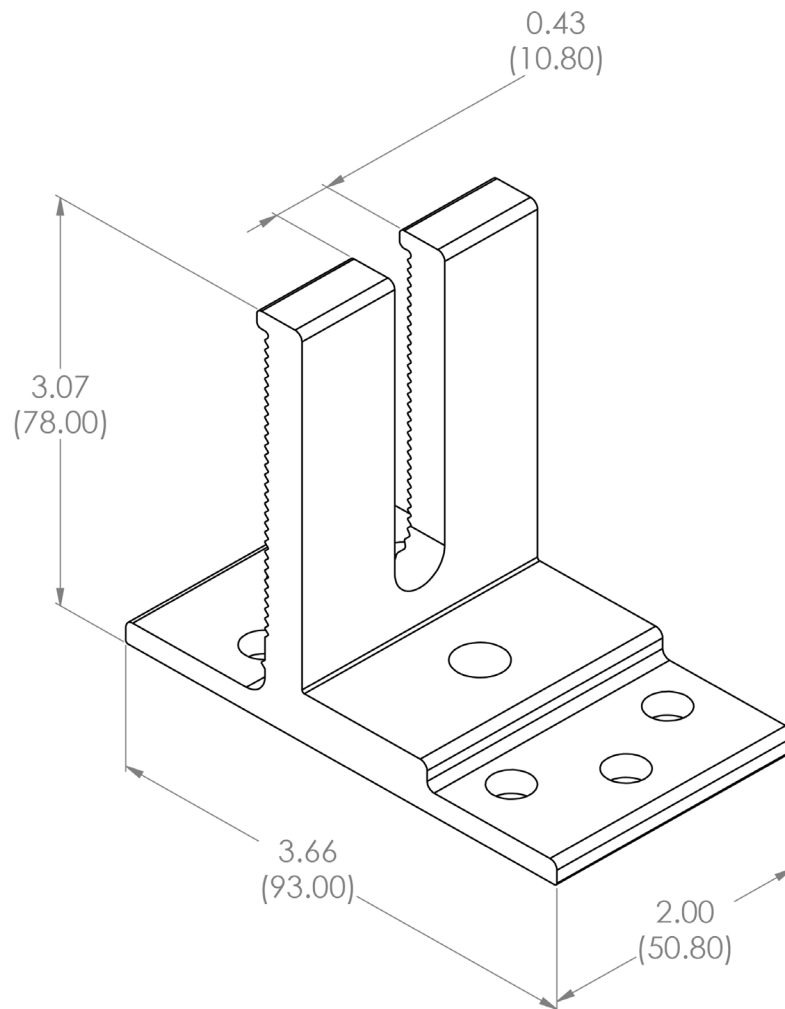
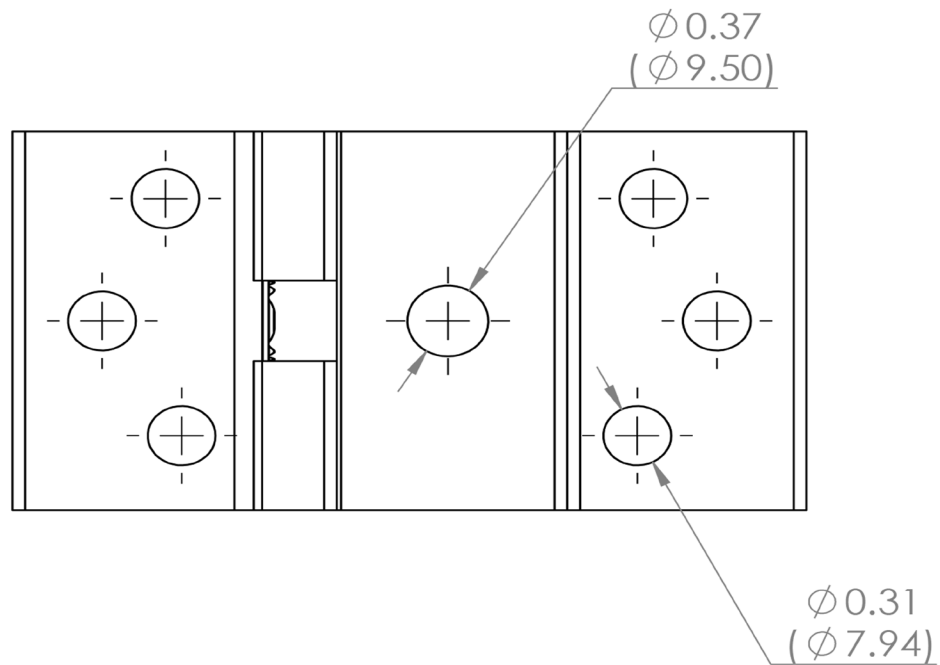

K2 Multi Mount

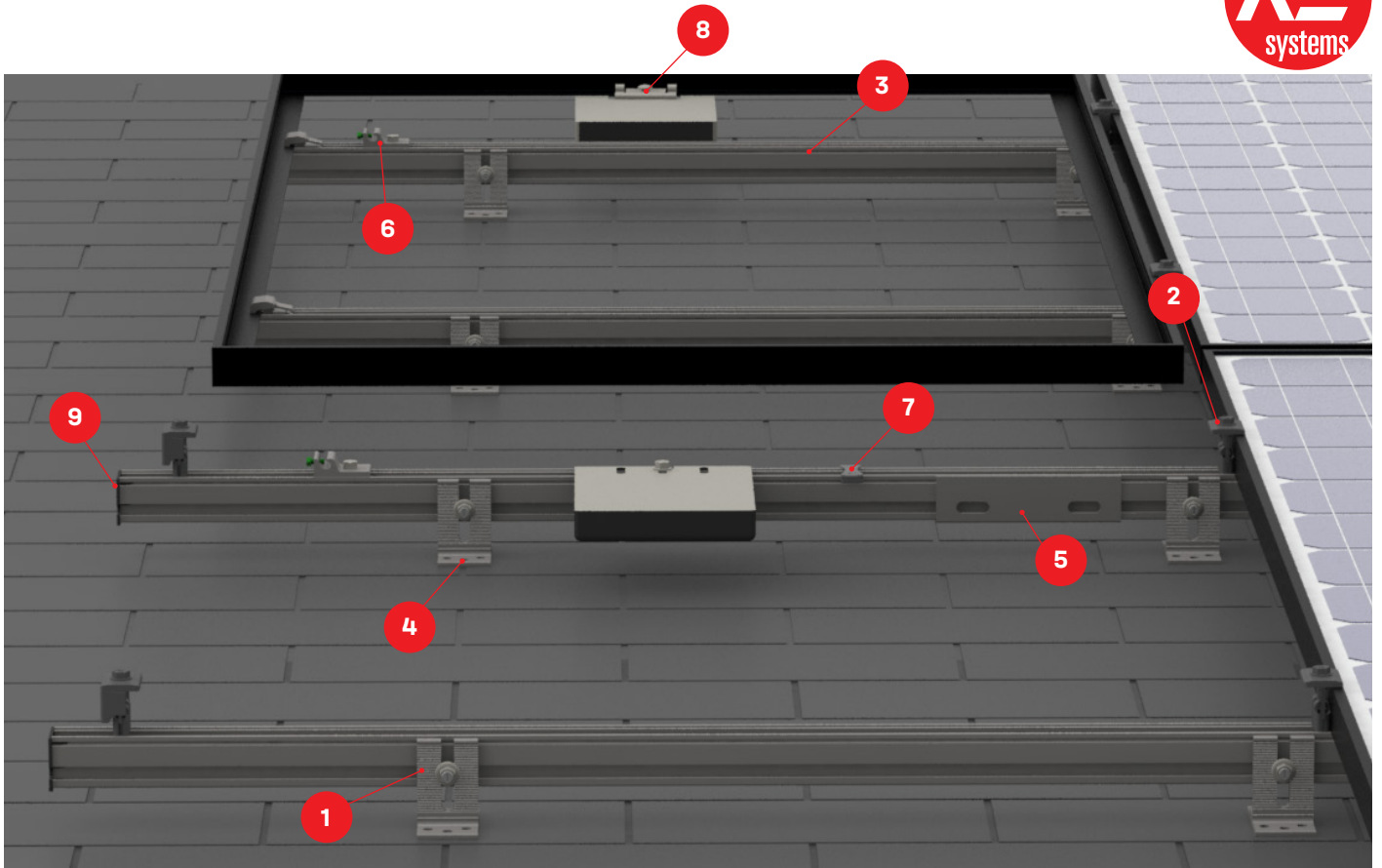

1 4000282/4000284

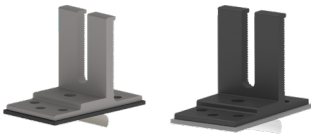

K2 Multi Mount

2 4000135/4000145
4000050-B

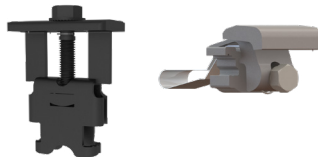

K2 Cross Clamp or Yeti Clamp

3 4000719, 4000720
4000721, 4000722

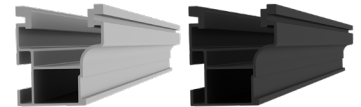

**CrossRail 44-X shown & listed
Works with all CR profile**

4 4000310 - Wood Screw



**DR #14 x 3" x 5/16 Hex Head
Screw**

5 4000051-T/4000052-T



**Toolless Rail Connector
CR 44-X**

6 4000006-H

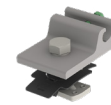

K2 Ground Lug

7 4000069
4000382
4005394



Wire Management
TC Wire Clip, SunRunner Clip,
Omega Clip

8 4000083
4000629-H

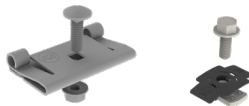

MLPE Mounting Kits
MLPE Module Frame Mount,
CR Microinverter & Opt Mount Kit

9 4000176



EndCap 44-X , K2



Connecting Strength

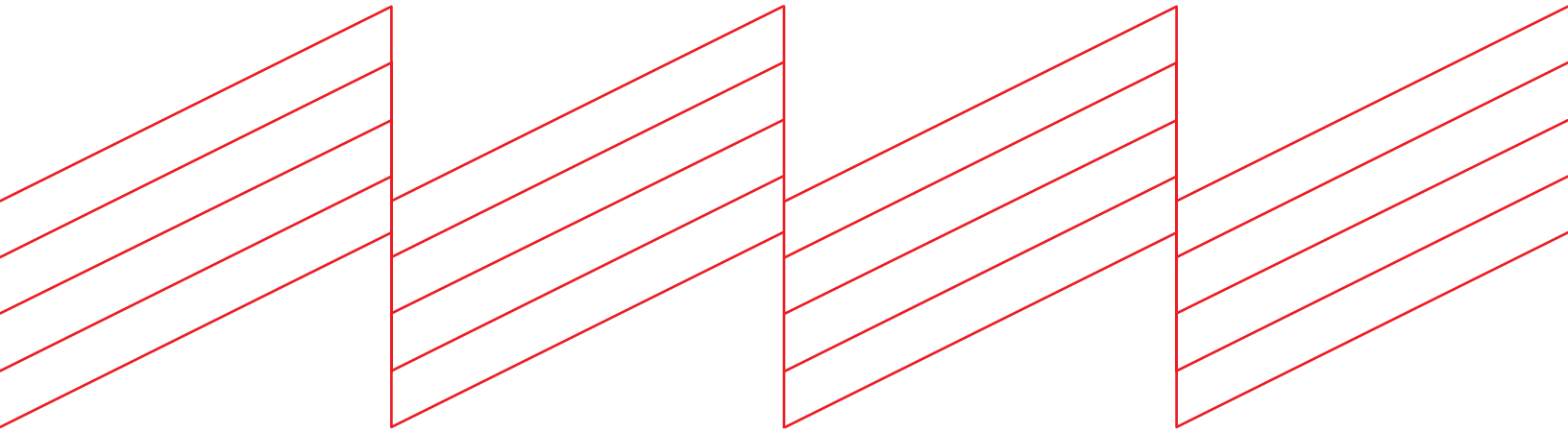

K2 Systems, LLC

4665 North Ave. Suite I • Oceanside, CA 92056 •
USA +1.760.301.5300 • infous@k2-systems.com
www.k2-systems.com

K2 Multi Mount, Kit Data Sheet V1 | 0424 • Subject to change
Product illustrations are exemplary and may differ from the original.