



powered by  carmanah®

Expansion Kits: RV Solar Power Kits:
GP-RV-80E GP-RV-80
GP-RV-95E GP-RV-95
GP-RV-160E GP-RV-160
Weekender SW
Weekender HD
Solar Elite
Solar Extreme

Owner's Manual





















Solar Extreme shown here

| Table of Contents | |
|---|----|
| RV Installation Parts and Checklist | 3 |
| 1.0 Installation Overview | 4 |
| 1.1 How Does the Go Power! RV Solar Kit Work | 4 |
| 1.2 Warnings | 4 |
| 1.3 Tools Required (Additional tools may be required) | 4 |
| 1.4 Weekender SW / Weekender HD / Solar Elite / Solar Extreme Installation | 5 |
| 2.0 Wiring the Solar Module and Power Cable | 5 |
| 3.0 Wiring Modules with MC4 Cables | 5 |
| 3.1 GP RV-80/95/160/Weekender HD/Weekender SW - Single Module System/MC4 Junction Box | 5 |
| 3.2 Solar Elite - Multimodule System/MC4 Junction Box | 5 |
| 3.3 Solar Extreme - Multimodule System/MC4 Junction Box | |
| 3.4 GP RV-80E/95E/160E - Expanding to a Multimodule System/MC4 Junction Box | 5 |
| 3.5 Modules with MC4 Connectors Wired to a Non-Potted Junction Box | 5 |
| 4.0 Routing Power Cable through the Fridge Vent | 6 |
| 4.1 Method 1 – Hole in Side of Vent | 6 |
| 4.2 Method 2 – Through Screen Grid | 6 |
| 5.0 Mounting the Solar Module | 6 |
| 5.1 Using the Mounting Feet | 6 |
| 6.0 Installing The GP-PWM Controller | 6 |
| 6.1 Mounting The GP-PWM Controller | 7 |
| 7.0 Connecting to the Battery & Solar Array | 7 |
| 7.1 Typical Battery Connection | 7 |
| 8.0 Limited Warranty | 7 |
| 8.1 General Warranty Issues | 8 |
| 8.2 Warranty Return Procedure | 8 |
| 8.3 Additional Information | 8 |
| 8.4 Out of Warranty Items | 9 |
| 9.0 System Glossary | 9 |
| 10.0 Diagrams | 11 |

| PART | Standard Kits | | | Expansion Kits | |
|---|--|--------------|----------------|------------------------|--|
| | GP-RV-80/95/160 *Weekender HD or SW | *Solar Elite | *Solar Extreme | GP-RV-80E/95E/ 160E | |
| 01. Ring Terminal Battery Connector | 2 | 2 | 2 | 0 | |
| 02. MC4 Cable with Male and Female MC4 Connectors | 1 | 1 | 1 | 0 | |
| 03. Tie Wrap | 6 | 6 | 6 | 0 | |
| 04. Positive MC4 Parallel Connector | 0 | 0 | 1 | 1 | |
| 05. Negative MC4 Parallel Connector | 0 | 0 | 1 | 1 | |
| 06. #10/32 Well Nut | 4 | 6 | 12 | 6 | |
| 07. #10/32 Well Nut Bolt | 4 | 6 | 12 | 6 | |
| 08. #10/32 Well Nut Flat Washer | 4 | 6 | 12 | 6 | |
| 09. #10/32 Well Nut Lock Washer | 4 | 6 | 12 | 6 | |
| 10. #6 Self-tapping Screws | 6 | 6 | 12 | 0 | |
| 11. Cable clamp | 6 | 6 | 12 | 0 | |
| 12. 1/4" Bolt | 4 | 6 | 12 | 6 | |
| 13. 1/4" Flat Washer | 4 | 6 | 12 | 6 | |
| 14. 1/4" Lock Washer | 4 | 6 | 12 | 6 | |
| 15. 1/4" Nut | 4 | 6 | 12 | 6 | |
| 16. Mounting Feet | 4 | 6 | 12 | 6 | |
| 17. Solar Module | 1 | 1 | 2 | 1 | |
| 18. GP-PWM Controller | 1 | 1 | 4 | 0 | |
| 19. ARM-UNI Mount (Optional) | 0 | 0 | 0 | 0 | |
| 20. # 10 1" Wood Screws | 4 | 4 | 8 | 4 | |

* The Solar Elite includes: GP-SW2000-12, GP-SWR-B-12, GP-DC Kit4, GPC-45-MAX and GP-TS.
 * The Weekender SW includes: GP-SW1500-12, GP-SW-Remote, GP-DC Kit3 and GP-TS.
 * The Solar Extreme includes: GP-SW3000-12, GP-SWR-B, GP-DC Kit 5, GPC-75-MAX and GP-TS

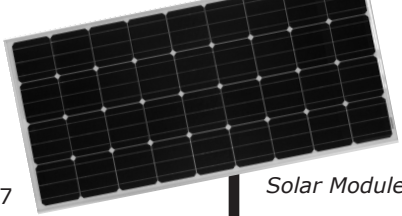
Parts Checklist

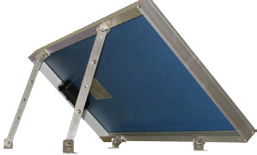
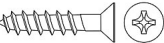
| | | | | | |
|----|---|----|---|----|---|
| 01 |  | 06 |  | 12 |  |
| 02 |  | 07 |  | 13 |  |
| 03 |  | 08 |  | 14 |  |
| 04 |  | 09 |  | 15 |  |
| 05 |  | 10 |  | 16 |  |
| | | 11 |  | 17 |  |
| | | | | 18 |  |
| | | | | |  |
| | | | | |  |
| | | | | |  |

(Optional)

1.0 Installation Overview

Congratulations on your purchase of a Go Power!™ RV Solar Power Kit. You have chosen a clean, quiet and sustainable way to provide power to your recreational vehicle. A Go Power!™ RV Solar Power Kit gives you the ability to dry camp while ensuring your batteries remain fully charged. The Go Power!™ RV Solar Power Kit allows you to enjoy the luxuries that electricity provides, without a campsite hookup. For simple battery maintenance or full-time live-aboard power, Go Power!™ RV Solar Power Kits are available in a variety of sizes and can be installed on RVs, campers, trailers, fifth wheels and motor homes.

1.1 How Does the Go Power!™ RV Solar Power Kit Work

The solar module converts the sun's energy into DC electricity and this electricity charges the battery. The battery stores the electricity, similar to a water tank storing water. The battery power may be used at any time to operate devices connected to the battery. To stop the battery from being overcharged by the solar module, a solar controller is connected between the two. The GP-PWM-30 controller will disconnect power from the solar module when the battery is fully charged.

Please read and understand all instructions before installing your new product for the easiest and safest installation. Before installing the kit, please review the installation diagram included in this Installation Manual. If you have any doubts as to this kit's compatibility with your RV, please contact your authorized Go Power!™ RV Dealer. It is advisable to retain this manual for future reference.

1.2 Warnings

Electrical Safety. Disconnect all power sources before attempting installation. Electricity can be very dangerous. Installation should be performed only by a licensed electrician or qualified personnel.

Solar Module Safety. Photovoltaic modules generate DC electricity when exposed to sunlight or other light sources. Contact with the electrically active parts of the module, such as terminals, can result in burns, sparks and lethal shock whether the module is connected or disconnected.

When modules are connected in parallel, amperages are additive. Consequently, a system assembled from photovoltaic modules can produce high amperages, which constitute an increased hazard.

Do not touch terminals while module is exposed to light. Cover the module face completely with opaque material to halt the production of electricity when installing or working with modules or wiring.

Battery Safety. Observe all safety precautions of the battery manufacturer when handling or working around batteries. When charging, batteries may produce explosive hydrogen gas. Work in a well ventilated area and use caution when making or removing electrical connections. Ensure wires are disconnected from their power sources when wiring. Do not expose battery to open flame, cigarettes or sparks. Shield skin and eyes from battery acid.

Wiring Safety Ensure all connections are tight and secure. Loose connections may generate sparks.

Work safely. Wear protective eyewear and appropriate clothing during installation. Use extreme caution when working with electricity and when handling and working around batteries. Use properly insulated tools only.

Observe correct polarity at all times. Any contact in reverse polarity, however brief, will cause the regulator and/or inverter fuse to blow and may damage the unit.

Do not exceed the voltage and current ratings of the regulator. The total current of the solar system is the sum of the short circuit current of the solar modules in parallel, multiplied by a safety factor of 1.25. The resulting system current is not to exceed the amperage rating of the regulator. The voltage of the array is the rated open circuit voltage of the solar modules and is not to exceed 26 volts for a 12 volt system. The current rating of the solar system is the sum of the Maximum Power Current (Imp) of the solar PV strings in parallel. The resulting system Imp current is not to exceed 30 A. The voltage of the array is the rated open circuit voltage (Voc) of the PV array and is not to exceed 56 V. If your solar system exceeds these ratings, contact your dealer for a suitable regulator alternative.



1.3 Tools Required (Additional tools may be required)

- | | |
|--|--------------------------------|
| a. Slot Screwdriver | g. Wire crimpers |
| b. # 2 Robertson Square Head Screwdriver | h. Electric hand drill |
| c. Keyhole saw | i. 1/16 and 3/8 inch drill bit |
| d. Punch or Awl | j. 5/16 and 7/16 inch wrench |
| e. Pliers | k. Sealant |
| f. Wire Strippers | |

1.4 Weekender SW / Weekender HD / Solar Elite/ Solar Extreme Installation

Refer to specific product manuals included in kits for correct product installation (ex. inverters, chargers and remotes).

2.0 Wiring the Solar Module and Power Cable

Please follow the directions in the appropriate section, depending on which kit you are about to install.

| Kit Model | Manual Section |
|---|----------------|
| GP-RV-80/95/155/Weekender HD/Weekender SW | Section 3.1 |
| Solar Elite | Section 3.2 |
| Solar Extreme | Section 3.3 |
| GP-RV-80E/95E/155E | Section 3.4 |

Wiring Diagrams (located at the end of the manual)

| | |
|---|-----------|
| MC4 Power Cables for RV Kits | Diagram-1 |
| Wiring Parallel Modules with MC4 Parallel Connectors | Diagram-2 |
| Parallel Wiring Between Standard and MC Junction Boxes | Diagram-3 |
| RV System Electrical Layout - RV/Off Grid | Diagram-4 |
| RV System Electrical Layout - Manual Power Switching | Diagram-5 |
| RV System Electrical Layout - Automatic Power Switching | Diagram-6 |

3.0 Wiring Modules with MC4 Cables

RV Kits with MC4 cables contain a potted or sealed junction box with a positive and negative MC4 connector. This is referred to as an MC4 junction box. MC4 connectors are either positive or negative and each connector has its polarity symbol embossed close to the connection point. To extend a cable from an MC4 junction box, a polarity opposite connector must be used. E.G. a negative connector must plug into a positive connector in order to extend it. Please remember, the polarity of an MC4 cable wire run is the polarity symbol on the connector closest to the MC4 junction box. It is advisable to attach a polarity sticker to the positive extension cable in order to avoid confusion.

Note:

This installation guide does not list all possible variations of available solar modules. This installation guide will address the assembly of standard Go Power! RV Solar Power Kits, which contain one, two or three solar modules connected in parallel for a 12 volt system. Expander Kits are available to add solar modules to an existing system.

3.1 GP-RV-80/95/155/Weekender HD/Weekender SW

Single Module System/MC Junction Box

RV Kits containing a single module with MC4 cables will be equipped with a single MC4 power cable that has both a male and female MC4 connection. This cable is meant to be cut in half leaving you with a 25' cable with a male MC4 and a 25' cable with a female MC4 connection. Refer to **Diagram-1**, "MC4 Power Cables for RV Kits."

3.2 Solar Elite

Multi Module System/MC4 Junction Box

RV Kits containing two modules with MC4 cables via an expansion kit will be equipped with a 50' MC4 power cable, a negative MC4 parallel connector and a positive MC4 parallel connector. Refer to **Diagram-2**, "Wiring Parallel Modules with MC4 Cables."

3.3 Solar Extreme

Multi Module System/MC4 Junction Box

RV Kits containing three modules with MC4 cables via two expansion kit will be equipped with a 50' MC4 power cable, two negative MC4 connectors and two positive MC4 connectors. Refer to **Diagram-2**, "Wiring Parallel Modules with MC Cables."

3.4 GP-RV-80E/95E/155E

Expanding to a Multi Module System/MC4 Junction Box

RV Kits containing two modules with MC4 cables via an expansion kit will be equipped with a 50' MC4 power cable, a negative MC4 parallel connector and a positive MC4 parallel connector. Refer to **Diagram-2**, "Wiring Parallel Modules with MC4 Cables."

3.5 Modules with MC4 Connectors Wired to a Non-Potted Junction Box

Please be aware that some modules are equipped with MC4 cables and a fully functioning non-potted Junction Box. In this case, it is recommended that the MC4 cables be used as described in **Section 3**. Do not connect the positive and negative MC4 cables from the same junction box together; this will short circuit the module.

4.0 Routing Power Cable through the Fridge Vent

Locate the refrigerator vent on the roof of the RV. Remove vent cover to gain access to the duct opening. Refer to **Figure 1**. Retain vent-fastening hardware.

4.1 Method 1 – Hole in Side of Vent

Drill a hole through the side of the vent (5/8" hole). Insert a rubber grommet (not included) into the hole. Insert the power cable (already wired to the solar module) through the hole and carefully route it to the battery. Be certain to leave enough slack to allow cable routing from module to vent along desired path.

4.2 Method 2 – Through Screen Grid

1. Thread power cable (already wired to solar module) carefully through the screen and into opening. Enlarge screen grid hole if necessary.
2. Avoid strapping the power cable to existing wire between the module and the battery. Allowing a few inches of space between the power cable and existing wire will lessen the chance of voltage loss through thermal conduction. Use cable clamps with the # 6 self-tapping screw and/or tie wraps every few feet along RV roof and interior route to battery.
3. Ensure all penetrations into the RV roof are watertight. Use an appropriate sealant as recommended by your RV Dealer to seal holes wherever necessary.
4. Replace vent cover.

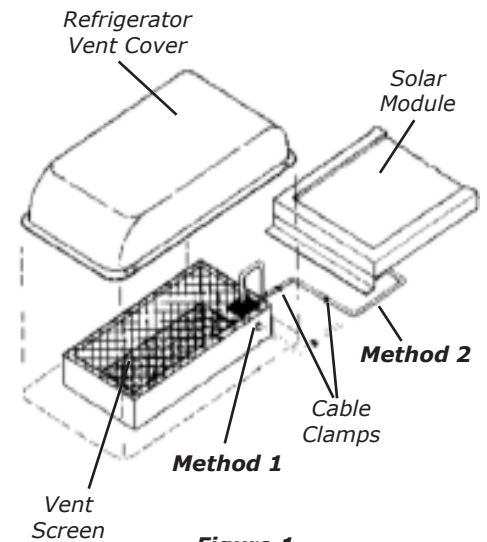

Figure 1

Caution:

The screen may have sharp edges or burrs.

5.0 Mounting the Solar Module

The solar modules may be horizontally mounted to the roof using the included mounting feet. An optional adjustable roof mount (ARM-UNI) is also available from Go Power!.

5.1 Using the Mounting Feet

1. Assemble the mounting feet onto the ends of the solar module using the 1/4" bolts, washers and nuts as shown in **Figure 2**.
2. Tighten nuts securely using a 7/16" wrench.
3. Place the module in a location that follows the criteria listed here:
 - Select a location where the mounting surface is at least 1/2" thick and strong enough to support mounting hardware, the solar module and wind loads
 - Minimize distance between the location of the solar module and the location where the power cable will enter the vehicle to connect to the battery
 - Place the module lengthwise along the roof to reduce wind loading on vehicles (if applicable)
 - Avoid internal wiring when selecting the spots for drilling the four mounting holes
 - Ensure obstacles, such as air conditioners, will not shade the solar module

Note: Place module so that you have room to expand the current system if needed.

4. Mark the mounting hole locations by using a pencil to trace through the holes in the mounting feet. Drill mounting holes only one inch deep with a 3/8" drill bit.
5. Use the appropriate sealant as recommended by your RV Dealer to ensure a watertight installation.
6. Gently insert the well-nuts into the drill holes so that only the topmost flange part remains above the roofline. Be careful not to push well-nuts through the holes.
7. Insert screws with lock washers and tighten. Do not overtighten.
8. If you are installing on a rubber roof with plywood underneath, it is acceptable to use wood screws instead of the well-nuts that are provided.

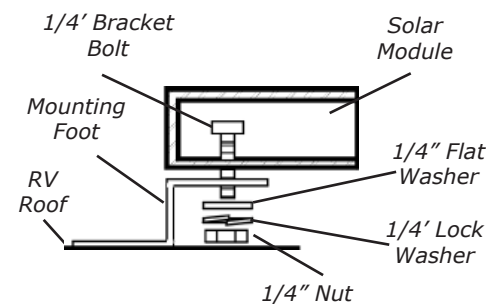

Figure 2

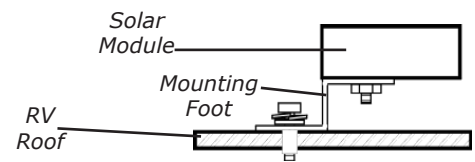

Figure 3

6.0 Installing The GP-PWM-30 Solar Controller

The GP-PWM -30 is included in all Go Power! RV Kits mentioned in this manual except for the Expansion Kits.

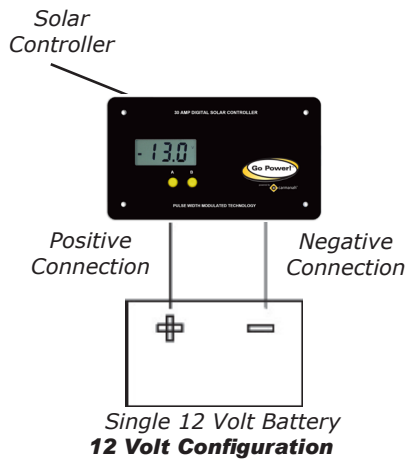

Figure 5

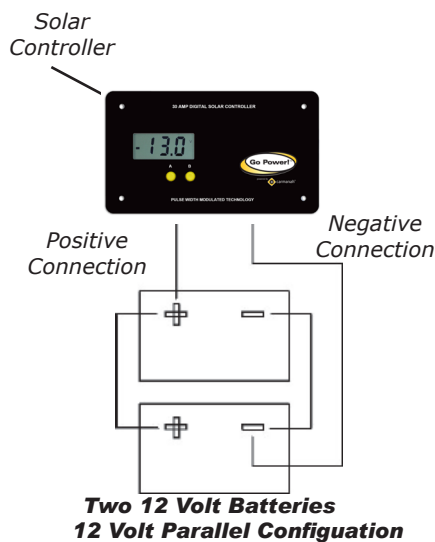

Figure 6

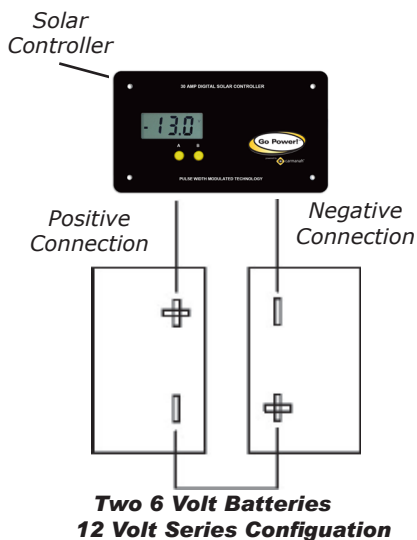

Figure 7

The GP-PWM-30 provides the necessary protection for the RV battery system. A condensed version of the installation instructions appear below. However, please read the full installation manual included with the GP-PWM-30 Solar Controller.

1. Disconnect or cover the solar modules and disconnect the batteries before commencing the GP-PWM-30 wiring.
2. Run the solar module power cable to the location of The GP-PWM-30. **Do not connect the wires to the controller or the batteries. Identify the polarity of the wires located on the battery and solar module (positive and negative).** Use coloured tape or mark wire ends with tags. Contacting the leads of the controller in reverse polarity, however brief, will cause the controller to go into lock out mode and the solar controller will need to be reset.
3. Wire the controller according to the terminal identification on the back of controller starting with the battery connections. Tighten the connections and then set the battery type on the controller (see controller manual for instruction). Then connect the solar module and tighten the connections.
4. Read The *GP-PWM-30 Manual* prior to installing.

6.1 Mounting The GP-PWM-30 Controller

The GP-PWM-30 should be mounted in a location relatively close to the battery, but easily seen for monitoring system operation. Wires must be run from the solar module to the controller and then to the battery. The GP-PWM-30 is designed to be flush mounted on the side of a cabinet or wall where the wiring can be accessed from the back. Allow two to three inches behind the unit. **The controller should be mounted indoors, in a dry location.**

1. Select a suitable location for the installation of the controller. Run the power cable from the solar module to the location selected.
2. Use the template included in the *GP-PWM-30 Manual* to mark the four mounting holes and the "cutting line for flush mounting". Drill the mounting holes. Use a keyhole or jig saw to cut along the rectangular outline you marked.
3. Wire the controller as shown in the *GP-PWM-30 Manual*. Use the leftover power cable to connect the controller to the batteries.
4. Mount the controller to the wall using the four wood screws provided. Ensure the back of the controller is protected from damage by any object.

7.0 Connecting to the Battery & Solar Array

It is recommended to connect directly to the battery wherever possible. You can also connect to the converter charger where the battery positive and negative wires connect to the converter.

1. Clean all corrosion from battery terminals before proceeding. Crimp ring terminals onto the negative and positive wires of the power cable to be attached to the battery.
2. Attach the negative (black) wire's 3/8" ring terminal to the RV battery. Check all electrical connections and apply a protective coating to battery terminals.

7.1 Typical Battery Connection

1. Single 12 Volt battery connection (See Figure 5)
2. Parallel 12 Volt battery connection (See Figure 6)
3. 6 Volt series battery connection (See Figure 7)

8.0 Disclaimer of Liability & Warranty

1. Go Power! warrants the Go Power!™ RV Solar Power Kit for a period of one (1) year from the date of shipment from its factory. This warranty is valid against defects in materials and workmanship for the one (1) year warranty period. It is not valid against defects resulting from, but not limited to:

- Misuse and/or abuse, neglect, or accident
- Exceeding the unit's design limits
- Improper installation, including, but not limited to, improper environmental

- protection and improper hook-up
- Acts of God, including lightning, floods, earthquakes, fire, and high winds
- Damage in handling, including damage encountered during shipment

- This warranty shall be considered void if the warranted product is in any way opened or altered. The warranty will be void if any eyelet, rivets, or other fasteners used to seal the unit are removed or altered, or if the unit's serial number is in any way removed, altered, replaced, defaced or rendered illegible.
- The one (1) year term of this warranty does not apply to equipment where another limited warranty is available. This may include but is not limited to, the solar controller five (5) years, the solar modules twenty-five (25) years and the inverter: modified sine wave inverter one (1) year, pure sine wave inverter two (2) years.

8.1 General Warranty Issues

Please visit gpelectric.com for our up-to-date General Warranty Issues

8.2 Warranty Return Procedure

Visit gpelectric.com to read the "frequently asked questions" section of our website to troubleshoot the problem. If trouble persists:

- Call your Go Power!™ Technical Support team (1-866-247-6527)
- Return defective product to place of purchase

8.3 Additional Information

Unless approved by Go Power! management, all product shipped collect to Go Power! will be refused. Test items or items that are not under warranty, or units that are not defective, will be charged a minimum bench charge of (\$50.00 US) plus taxes and shipping. A 15% restocking charge will be applied on goods returned and accepted as "new" stock.

8.4 Out of Warranty Items

Go Power! electronic products are non-repairable, Go Power!™ does not perform repairs on its products nor does it contract out those repairs to a third party. Go Power!™ does not supply schematics or replacement parts for any of its electronic products.

9.0 System Glossary

Visit gpelectric.com for our Glossary of Terms

10.0 Diagrams

| | |
|---|-----------|
| MC4 Power Cables for RV Kits | Diagram-1 |
| Wiring Parallel Modules with MC4 Parallel Connectors | Diagram-2 |
| Parallel Wiring Between Standard and MC4 Junction Boxes | Diagram-3 |
| RV System Electrical Layout - RV/Off Grid | Diagram-4 |
| RV System Electrical Layout - Manual Power Switching | Diagram-5 |
| RV System Electrical Layout - Automatic Power Switching | Diagram-6 |

Diagram 1

MC4 Power Cabels For RV Kits

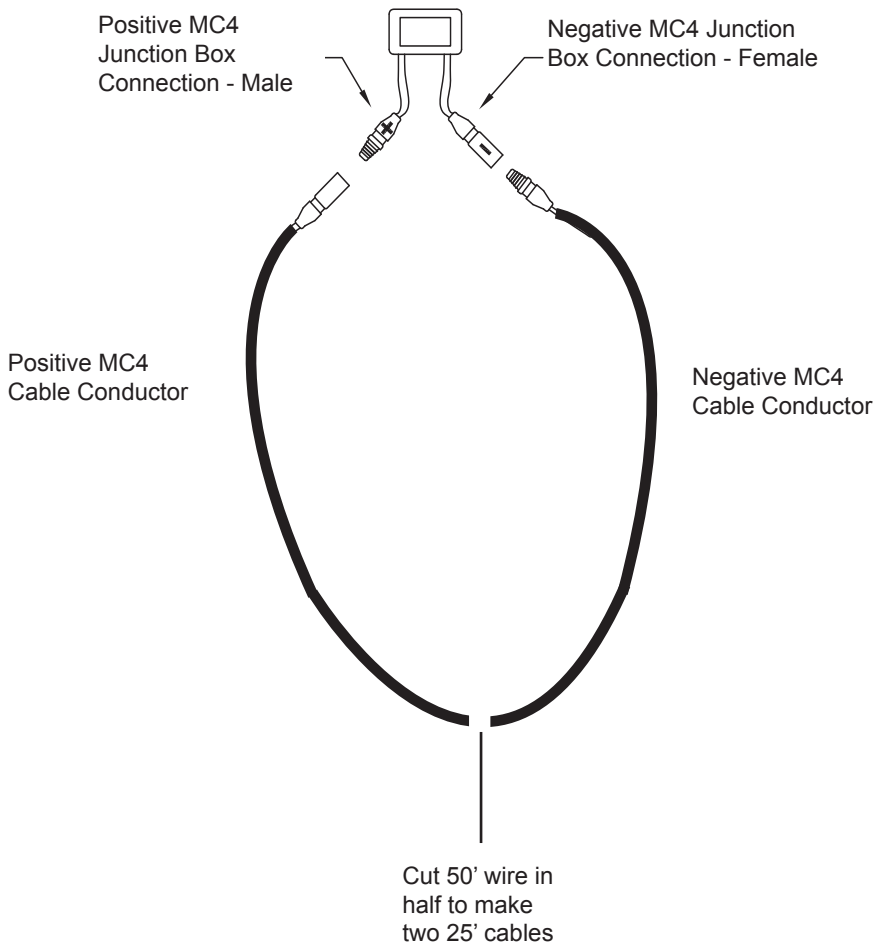

The MC4 power cable is usually the final connection between the solar array and the solar controller. If it has not already been done, cut the MC power cable into two pieces so that there is a positive conductor cable and negative conductor cable.

1. Cover the solar module(s) with an opaque material. Attach the appropriate MC4 power cable conductor to the positive and negative connectors of the MC4 junction box. If you have more than one module, refer to the specific diagram for wiring a parallel MC4 connection.
2. Run the positive and negative MC4 cable conductors from the solar array to the solar controller. Attach a positive polarity label to the end of the positive conductor. If the positive conductor needs to be shortened and the polarity label is removed, remember to re-label it as both positive and negative conductors look exactly the same. Leave a few feet of cable at the solar controller in case of future adjustment.

Note: solar module junction box and MC4 cables many not be exactly as shown.

Diagram 2

Wiring Parallel (2) Modules with MC4 Parallel Connectors

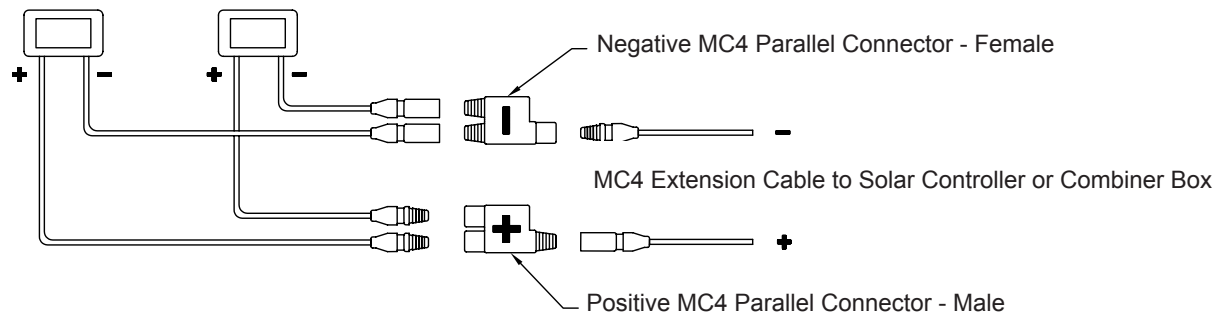

MC4 Cable Connections for 2 Parallel Modules

E.G. Two 12V modules at 12V



MC4 Parallel - Male



MC4 Parallel - Female

Note: solar module junction box and MC4 cables many not be exactly as shown.

Diagram 3

Parallel Wiring Between a Standard Junction Box and an MC4 Cable Junction Box

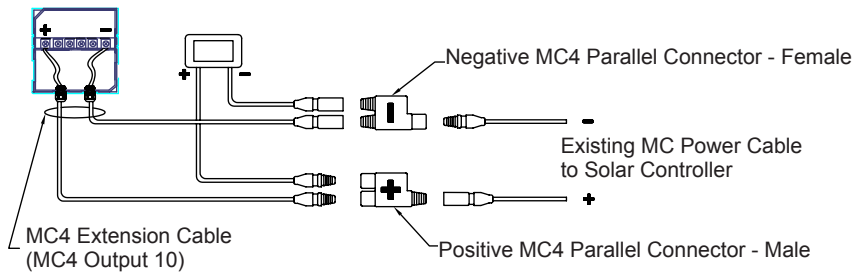

Parallel Wiring Between a Standard Junction Box and an Existing MC4 Cable Junction Box

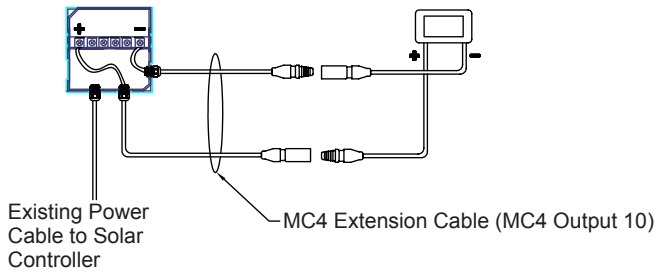

Note: solar module junction box and MC4 cables may not be exactly as shown.



MC4 Parallel - Male



MC4 Parallel - Female

Diagram 4

RV Electrical Layout - RV / Off Grid

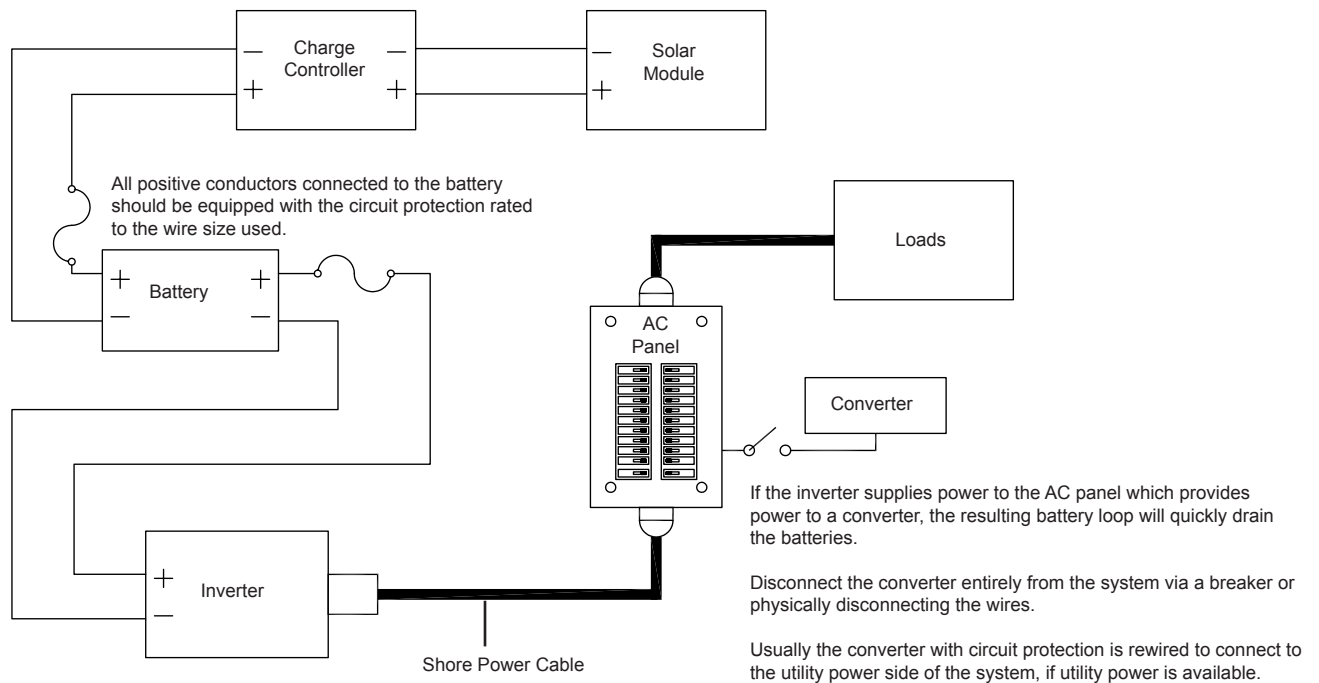
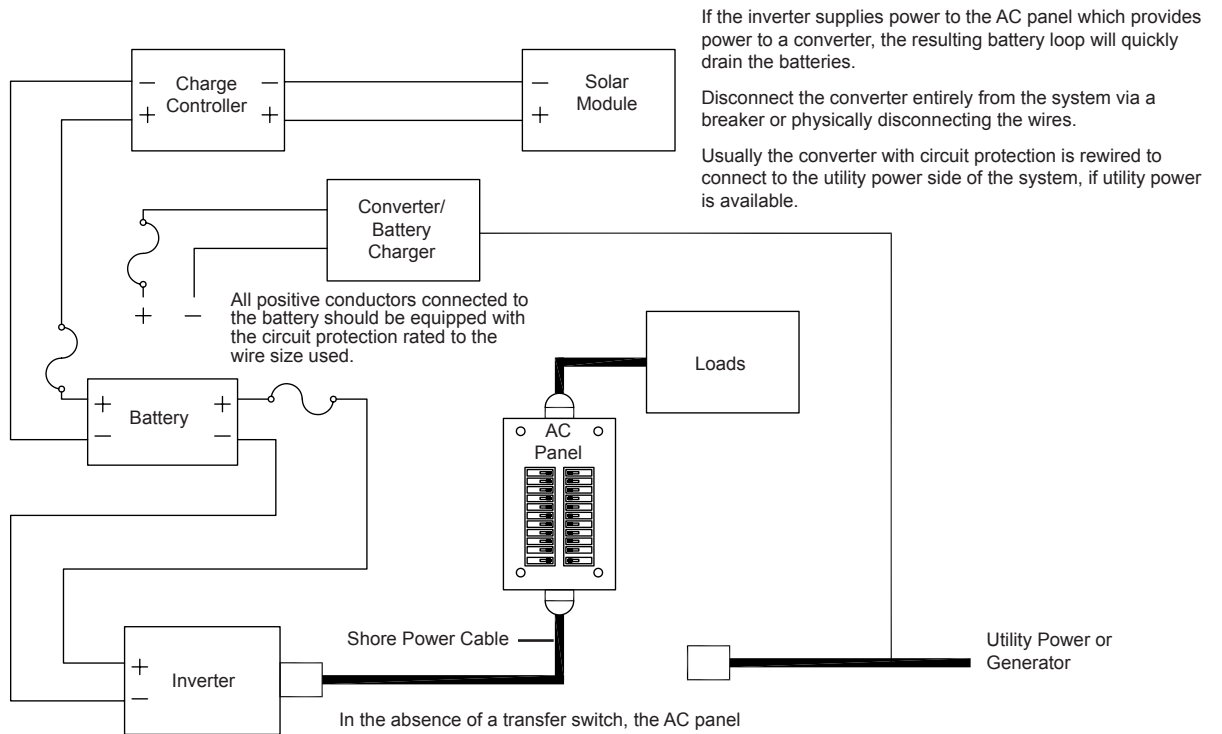

Diagram is recommended wiring only. Compliance with governing electrical code is assumed.

In no event will Carmanah be liable to any party or for any direct, indirect, special or other consequential damages resulting from use of this diagram.

Diagram 5

RV Electrical Layout - Two AC Power Sources No Transfer Switch - Manual Switching



In no event will Carmanah be liable to any party or for any direct, indirect, special or other consequential damages resulting from use of this diagram.

Diagram is recommended wiring only. Compliance with governing electrical code is assumed.

Diagram 6

RV Electrical Layout - Two AC Power Sources with Automatic Transfer Switch

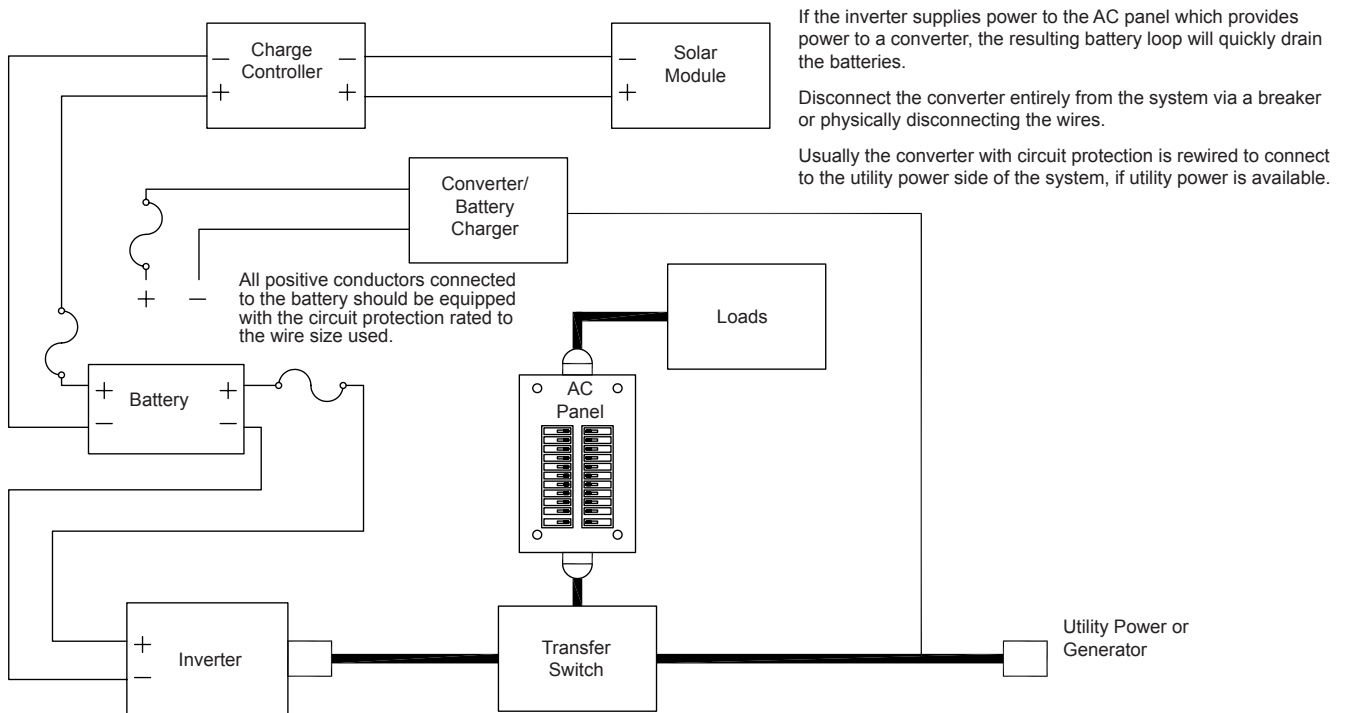

In no event will Carmanah be liable to any party or for any direct, indirect, special or other consequential damages resulting from use of this diagram.

Diagram is recommended wiring only. Compliance with governing electrical code is assumed.



powered by  carmanah®

The Carmanah logo consists of a yellow diamond shape with a black circle in the center, containing a white starburst or sun-like symbol.

© 2013 GO POWER!™ By Carmanah Technologies

MOBI_MAN_GP-RV Install Kit and Systems_160.indd