

INSTALLATION MAP



To Sheet: \_\_\_\_\_

Panel Group: Tilt: Sheet ____ of ____	Customer:				Installer:				N S E W 	
	1	2	3	4	5	6	7	8	9	
A										
B										
C										
D										
E										
F										
G										
H										
J										
K										
L										
M										

To Sheet: \_\_\_\_\_

To Sheet: \_\_\_\_\_

Scan completed map and upload it to Enphase. Click "Add a New System" at <https://enphase.com/installers/apps>.

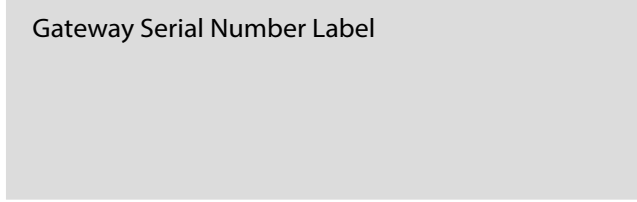

© 2024 Enphase Energy. All rights reserved. Enphase, the e and CC logos, IQ, and certain other marks listed at <https://enphase.com/trademark-usage-guidelines> are trademarks of Enphase Energy, Inc. in the U.S. and other countries. Data subject to change. 2024-11-19.

Enphase Support: <https://enphase.com/contact/support>

To Sheet: \_\_\_\_\_

QUICK INSTALL GUIDE

Install the IQ8 Series Microinverter

To install IQ8 Series Microinverters, read and follow all warnings and instructions in this guide and the [IQ8 Series Microinverter installation and operation manual](#). Safety warnings are listed at the end of this guide.

The Enphase microinverter models listed in this guide do not require grounding electrode conductors (GEC), equipment grounding conductors (EGC), or grounded conductors (neutral). The microinverter has a class II double-insulated rating, which includes ground fault protection (GFP). To support GFP, use only PV modules with DC cables labeled PV wire or PV cable.

**IMPORTANT: IQ8 Series Microinverters require the IQ Cable. An IQ Gateway is required to monitor the performance of the IQ Microinverters. The IQ accessories work only with IQ8 Series Microinverters.**

The IQ Series Microinverters include AC and DC connectors integrated into the bulkhead. The AC port connects to an IQ Cable. UL evaluates the DC port for intermateability with Staubi made MC4 connectors. The DC port of the inverter must be mated with Staubi made MC4 connectors.

- NOTE:** 1) After you log in to your Enphase Account from the Enphase Installer App, scan the microinverter serial numbers (ID bar code) and connect to the IQ Gateway to track the system installation progress.  
2) Installer must check the manufacturing date of the products to ensure that the installation date is within one year of the manufactured date of the products. Contact your local distributor to validate the date code.

Preparation

- A) Download the Enphase Installer App and log in to your Enphase Account. With this app, scan microinverter serial numbers (ID bar code) and connect to the IQ Gateway to track system installation progress. To download, go to <https://enphase.com/installers/apps> or scan the below QR code.



- B) Refer to the following table and check electrical compatibility at: <https://enphase.com/installers/microinverters/calculator>.

Model	DC connector	Typical PV module* cell count
IQ8MC-72-M-US IQ8AC-72-M-US IQ8HC-72-M-US	Staubli MC4	Pair with 54-cell/108 half-cell, 60-cell/120 half-cell, 66-cell/132 half-cell, or 72-cell/144 half-cell
IQ8X-80-M-US		Pair with 96-cells, 80-half-cut cell, and 88-half-cut-cell

\* Enphase IQ Series Microinverters are compatible with bifacial PV modules if the temperature-adjusted electrical parameters (maximum power, voltage, and current) and bifacial gain of the modules are within the allowable input parameters range. In evaluating the amount of bifacial gain, follow the recommendations of the module manufacturers.

- C) In addition to the Enphase microinverters, PV modules, and racking, you need these Enphase accessories:

- IQ Gateway (model ENV-IQ-AMI-240, ENV2-IQ-AMI-240) communications gateway or IQ Combiner (check [enphase.com](https://enphase.com) for models) is required to monitor solar production
- Tie wraps or IQ Cable Clips (Q-CLIP-100)
- IQ Sealing Caps (Q-SEAL-10) for any unused connectors on the IQ Cable
- IQ Terminator (Q-TERM-10) is needed at the end of each AC cable segment
- IQ Disconnect Tool (Q-DISC-10)
- IQ Field Wireable Connectors (male and female: Q-CONN-10M and Q-CONN-10F)
- IQ Cable:

Cable model	Connector spacing*	PV module orientation	Connectors per box
Q-12-10-240	1.3 m	Portrait (all)	240
Q-12-17-240	2.0 m	Landscape (60 and 66-cell)	240
Q-12-20-200	2.3 m	Landscape (72-cell)	200

\* Allows for 30 cm of cable slack

- D) Check that you have these items:
- AC junction box.

- Tools: screwdrivers, wire cutter, voltmeter, torque wrench, sockets, power drill or impact driver, and wrenches for mounting hardware.
- E) Protect your system with lightning and surge suppression devices. It is also important to have insurance that protects against lightning and electrical surges.
- F) Check compatibility when expanding an IQ7 system with IQ8 Microinverters:
  - IQ8 Series Microinverters can be added to existing IQ7 systems on the same IQ Gateway in the following grid-tied configuration only:
    - Solar Only
    - Solar + Battery (IQ Battery 3T/10T and IQ Battery 5P) without backup
  - IQ7 Series Microinverters cannot be added on a site with existing IQ8 Series Microinverters on the same gateway. Mixed system of IQ7, IQ8 will not support IQ8 specific PCS features and grid-forming capabilities.
  - If IQ7 Microinverters need to be added on a site on the same gateway where IQ8 Microinverters are present, then IQ8 Microinverters need to be retired and recommissioned after commissioning the IQ7 Microinverters.
  - Addition of IQ8 Series Microinverters to existing IQ7 systems with IQ System Controller is not supported if added on the same IQ Gateway.
- G) Plan your AC branch circuits to meet the following limits for a maximum number of microinverters per branch when protected with a 20-amp over current protection device (OCPD).

Maximum* IQ8 Series Microinverters per AC branch circuit (single-phase)			
IQ8MC (240 V)	IQ8AC (240 V)	IQ8HC (240 V)	IQ8X (240 V)
12	11	10	10
IQ8MC (208 V split-phase)	IQ8AC (208 V split-phase)	IQ8HC (208 V split-phase)	IQ8X (208 V)
10	9	9	9
IQ8MC (220 V)	IQ8AC (220 V)	IQ8HC (220 V)	IQ8X (220 V)
-	-	9	-

\* Limits may vary. Refer to local requirements to define the number of microinverters per branch in your area.

**NOTE:** For a mixed system containing both IQ7 and IQ8 Microinverters on the same branch, ensure that the total maximum continuous output current of all microinverters on the branch does not exceed 16 A.

- H) Size the AC wire gauge to account for voltage rise. Select the correct wire size based on the distance from the IQ Cable's beginning to the load center breaker. Design for a voltage rise of less than 2% for these sections. Refer to the [Calculating AC Line Voltage Rise for IQ-Series Micros with Q Cable](#) tech brief for more information.

**Best practice:** Center-feed the branch circuit to minimize voltage rise in a fully-populated branch.

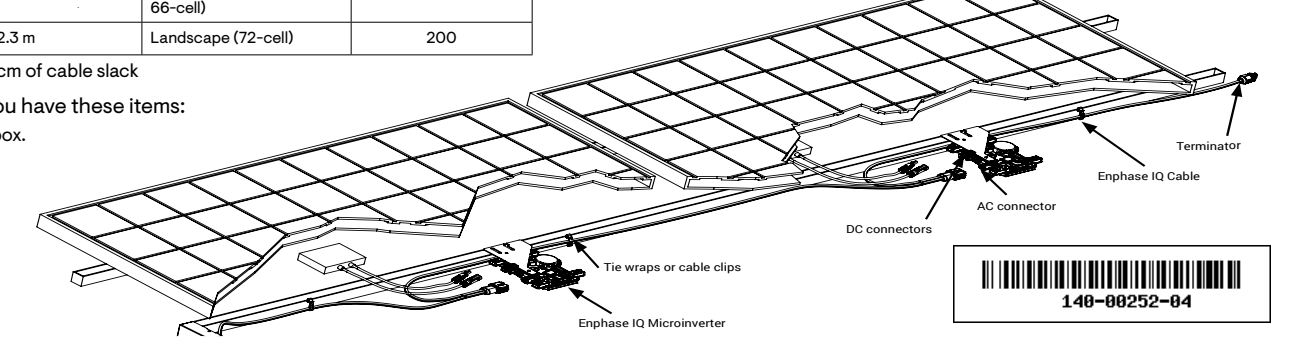

## Installation

### 1 Position the IQ Cable

- Plan each cable segment to allow connectors on the IQ Cable to align with each PV module. Allow extra length for slack, cable turns, and any obstructions.
- Mark the approximate centers of each PV module on the PV racking.
- Lay out the cabling along the installed racking for the AC branch circuit.
- Cut each segment of cable to meet your planned needs.



**WARNING:** When transitioning between rows, secure the cable to the rail to prevent cable or connector damage. Do not count on the connector to withstand tension.

### 2 Position the junction box

- Verify that AC voltage at the site is within range:

Service type and voltage:	L1 - L2
240 V single-phase	211 to 264 VAC
208 V single-phase	183 to 229 VAC
220 V single-phase	198 to 264 VAC

- Install a junction box at a suitable location on the racking.
- Provide an AC connection from the junction box back to the electricity network connection using equipment and practices as required by local jurisdictions.
 

**NOTE:** All installations require that you must use the IQ Gateway to commission the microinverters to propagate correct grid profile settings. This also ensures the microinverter's firmware is upgraded whenever a newer version is available.

### 3 Mount the microinverters

- The microinverters should be mounted beneath the modules either horizontally, bracket side up, or vertically. They must be protected from direct exposure to rain, sun, UV, and other harmful weather events. Refer to the image below for clearance requirements during vertical mounting. For horizontal mount, allow a minimum of 1.9 cm (0.75 inches) between the roof and the microinverters. Also, allow 1.3 cm (0.5 inches) between the back of the PV module and the top of the microinverters. For vertical mount, maintain >30 cm (12 inches) clearance from the edges of the PV module to protect the microinverters from direct exposure to rain, UV, and other harmful weather events.



**WARNING:** Install the microinverter under the PV module to avoid direct exposure to rain, UV, and other harmful weather events. Do not mount the microinverter upside down.

- Torque the mounting fasteners (0.25 inches or 0.31 inches) as follows. Do not over-torque.
  - 6 mm (0.25 inches) mounting hardware: 5 N m (45 to 50 lbs)
  - 8 mm (0.31 inches) mounting hardware: 9 N m (80 to 85 lbs)
  - When using UL 2703 mounting hardware, use the manufacturer's recommended torque value

### Horizontal mount

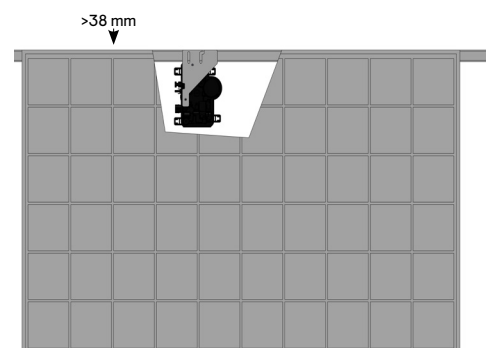

### Vertical mount

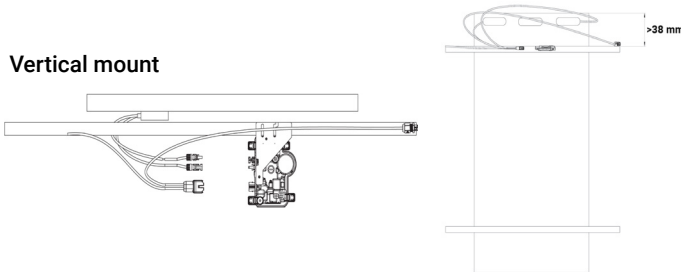

### 4 Create an installation map

Create a paper installation map to record microinverter serial numbers and positions in the array.

- Peel the removable serial number label from each microinverter and affix it to the respective location on the paper installation map.
- Peel the label from the IQ Gateway and affix it to the installation map.
- Always keep a copy of the installation map for your records.

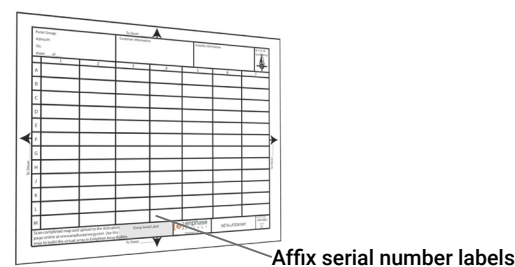

Affix serial number labels

### 5 Manage the cabling

- Use IQ Cable Clips or tie wraps to attach the cable to the racking. The cable must be supported at least every 1.8 m (6 feet).
- Dress any excess cabling in loops to avoid contacting the roof. Do not form loops smaller than 12 cm (4.75 inches) in diameter.

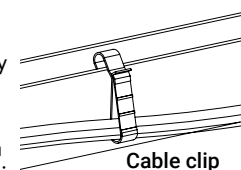

### 6 Connect the microinverters

- Connect the microinverter. Listen for a click as the connectors engage.
- Cover any unused connectors on the AC cable with IQ Sealing Caps. Listen for a click as the sealing caps engage.

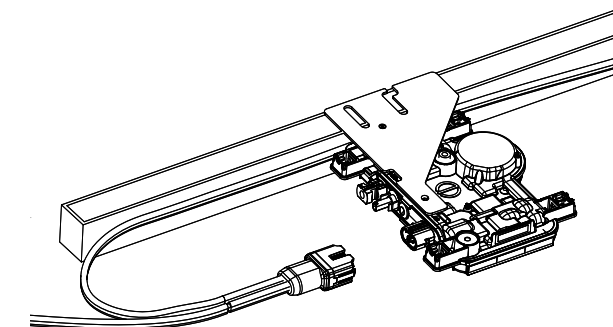

**WARNING:** Install sealing caps on all unused AC connectors, as these connectors become live when the system is energized. Sealing caps are required for protection against moisture ingress.

To remove a sealing cap or AC connector, you must use an IQ Disconnect Tool.

### 7 Terminate the unused end of the cable

- Remove 13 mm (0.5 inches) of the cable sheath from the conductors. Use the terminator loop to measure.

### Terminator body

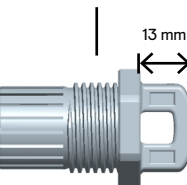

- Slide the hex nut onto the cable.
- Insert the cable into the terminator body so that each of the two wires lands on opposite sides of the internal separator. There is a grommet inside of the terminator body that should remain in place.

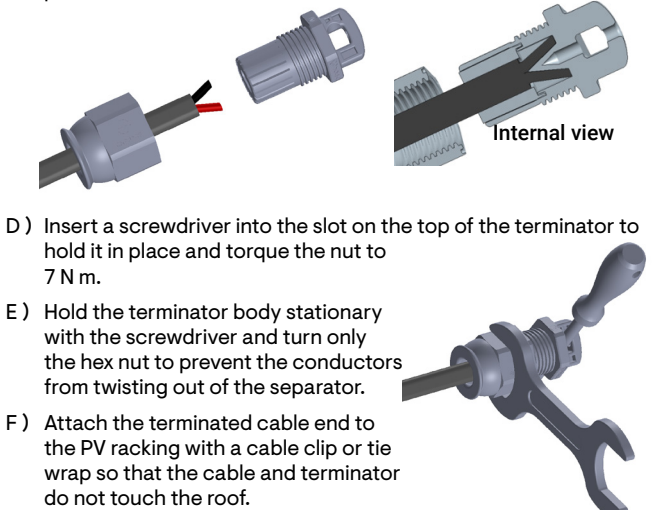

- Insert a screwdriver into the slot on the top of the terminator to hold it in place and torque the nut to 7 N m.
- Hold the terminator body stationary with the screwdriver and turn only the hex nut to prevent the conductors from twisting out of the separator.
- Attach the terminated cable end to the PV racking with a cable clip or tie wrap so that the cable and terminator do not touch the roof.



**WARNING:** The terminator cannot be reused. If you unscrew the nut, you must discard the terminator.

### 8 Complete installation of the junction box

- Connect the IQ Cable to the junction box.
- The IQ Cable uses the following wiring color code:

Wire colors
Black - L1
Red - L2

## Revision history

Revision	Date	Description
140-00252-04	November 2024	Updated IQ8 Microinverter compatibility with existing IQ7 systems.
140-00252-03	September 2023	Added IQ8X microinverter
Previous releases		

### 9 Connect the PV modules



**DANGER!** Electric shock hazard. The DC conductors of this PV system are ungrounded and may be energized.

- Attach the Enphase DC bulkhead adapters to the microinverters, if required. Ensure they are fully seated. Do not reverse the adapter connections.
- Connect each PV module's DC leads to the microinverter's DC input connectors or adapters.
- Check the LED on the connector side of the microinverter. The LED flashes green six times when DC power is applied.
- Mount the PV modules above the microinverters.

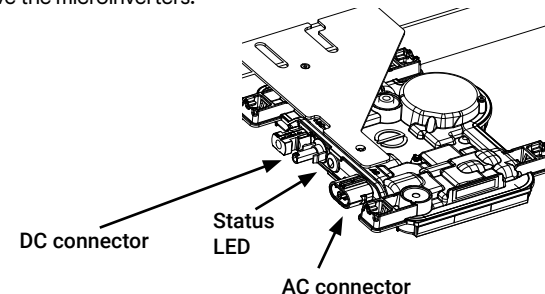

### 10 Energize the system

- Turn ON the branch circuit's AC disconnect or circuit breaker.
- Turn ON the main utility-grid AC circuit breaker. Your system will start producing power after a five-minute wait time.
- Check the LED on the connector side of the microinverter.

LED	Indicates
Flashing green	Normal operation. AC grid function is normal, and there is communication with the IQ Gateway.
Flashing orange	The AC grid is normal, but there is no communication with the IQ Gateway.
Flashing red	The AC grid is either not present or not within specification.
Solid red	There is an active "DC Resistance Low, Power Off" condition. To reset, refer to the <a href="#">IQ Gateway installation and operation manual</a> .

## Activate monitoring and controls

After installing the microinverters, follow the IQ Gateway quick install guide procedures to activate system monitoring, set up grid management functions, and complete the installation.

- Connect the IQ Gateway
- Detect devices
- Connect to the Enphase Installer Platform
- Register the system
- Build the virtual array

## Enphase connector rating

Enphase connectors on the cable assemblies in the following table have a maximum current of 20 A, a Maximum OCPD of 20 A, and maximum ambient temperature of -40° to 79°C (-40° to 174.2°F) and are rated for disconnection under load.

Part number	Model	Maximum voltage
840-00387	Q-12-10-240	250 VAC
840-00388	Q-12-17-240	250 VAC
840-00389	Q-12-20-200	250 VAC

## PV rapid shutdown equipment (PVRSE)

This product is UL Listed as a PV rapid shutdown equipment and conforms with NEC-2014, NEC-2017, and NEC-2020 section 690.12 and C22.1-2018 Rule 64-218 rapid shutdown of PV systems for AC and DC conductors when installed according to the following requirements:

- Microinverters and all DC connections must be installed inside the array boundary. Enphase further requires installing the microinverters and DC connections under the PV module to avoid direct exposure to rain, UV, and other harmful weather events.
- The array boundary is defined as 305 mm (1 ft.) from the array in all directions or 1 m (3 ft.) from the point of entry inside a building.

This rapid shutdown system must be provided with an initiating device and (or with) a status indicator, which must be installed in a location accessible to first responders or connected to an automatic system that initiates rapid shutdown upon the activation of a system disconnect or activation of another type of emergency system. The initiator shall be listed and identified as a disconnecting means that indicates whether it is in the "off" or "on" position. Examples are:

- Service disconnecting means
  - PV system disconnecting means
  - Readily accessible switch or circuit breaker
- The handle position of a switch or circuit breaker is suitable for use as an indicator. Refer to NEC or CSA C22.1-2015 for more information.

Additionally, in a prominent location near the initiator device, a placard or label must be provided with a permanent marking including the following wording: 'PHOTOVOLTAIC SYSTEM EQUIPPED WITH RAPID SHUTDOWN' The term 'PHOTOVOLTAIC' may be replaced with 'PV.' The placard, label, or directory shall be reflective, with all letters capitalized and having a minimum height of 9.5 mm (0.37 inches) in white on a red background.

## SAFETY

**IMPORTANT SAFETY INSTRUCTIONS SAVE THIS INFORMATION.** This guide contains important instructions to follow during the installation of the IQ8MC, IQ8AC, IQ8X, and IQ8HC microinverters.

	<b>WARNING:</b> Hot surface
	<b>WARNING:</b> Refer to safety instructions
	<b>DANGER:</b> Risk of electric shock
	<b>Refer to the manual</b>
	<b>Double Insulated</b>

### Safety symbols

	<b>DANGER:</b> Indicates a hazardous situation, which, if not avoided, will result in death or serious injury.
	<b>WARNING:</b> Indicates a situation where failure to follow instructions may be a safety hazard or cause equipment malfunction. Use extreme caution and follow instructions carefully.
	<b>WARNING:</b> Indicates a situation where failure to follow instructions may result in burn injury.
	<b>NOTE:</b> Indicates information particularly important for optimal system operation.

### General safety

	<b>DANGER:</b> Risk of electric shock. Do not use Enphase equipment in a manner not specified by the manufacturer. Doing so may cause death or injury to persons or damage to equipment.
	<b>DANGER:</b> Risk of electric shock. Be aware that installation of this equipment includes risk of electric shock.
	<b>DANGER:</b> Risk of electric shock. The DC conductors of this photovoltaic system are ungrounded and may be energized.
	<b>DANGER:</b> Risk of electric shock. Always de-energize the AC branch circuit before servicing. Never disconnect the DC or AC connectors under load.
	<b>DANGER:</b> Risk of electric shock. Risk of fire. Only use electrical system components approved for wet locations.
	<b>DANGER:</b> Risk of electric shock. Risk of fire. Only qualified personnel should troubleshoot, install, or replace Enphase microinverters or the IQ Cable and accessories.

Enphase Support: <https://enphase.com/contact/support>

	<b>DANGER:</b> Risk of electric shock. Risk of fire. Ensure that all AC and DC wiring is correct and that none of the AC or DC wires are pinched or damaged. Ensure that all AC junction boxes are properly closed.
	<b>DANGER:</b> Risk of electric shock. Risk of fire. Do not exceed the maximum number of microinverters in an AC branch circuit as listed in this guide. You must protect each microinverter AC branch circuit with a 20 A maximum breaker or fuse, as appropriate.
	<b>DANGER:</b> Risk of electric shock. Risk of fire. Only qualified personnel may connect the Enphase microinverter to the utility grid.
	<b>WARNING:</b> Risk of equipment damage. Enphase male and female connectors must only be mated with the matching male/female connector.
	<b>WARNING:</b> Before installing or using the Enphase microinverter, read all instructions and cautionary markings in the technical description, on the Enphase microinverter system, and on the photovoltaic (PV) equipment.
	<b>WARNING:</b> Do not connect Enphase microinverters to the grid or energize the AC circuit(s) until you have completed all of the installation procedures and have received prior approval from the electrical utility company.
	<b>WARNING:</b> When the PV array is exposed to light, DC voltage is supplied to the PCE.
	<b>NOTE:</b> To ensure optimal reliability and to meet warranty requirements, install the Enphase microinverters and IQ Cable according to the instructions in this guide.
	<b>NOTE:</b> Provide support for the IQ Cable at least every 1.8 m (6 ft.).
	<b>NOTE:</b> Perform all electrical installations in accordance with all applicable local electrical codes, such as the Canadian Electrical Code, Part 1 and NFPA 70 (NEC).
	<b>NOTE:</b> Protection against lightning and resulting voltage surge must be in accordance with local standards.

### Microinverter safety

	<b>DANGER:</b> Risk of electric shock. Risk of fire. Do not attempt to repair the Enphase microinverter; it contains no user-serviceable parts. If it fails, contact Enphase Support to obtain an RMA (return merchandise authorization) number and start the replacement process. Tampering with or opening the Enphase microinverter will void the warranty.
	<b>DANGER:</b> Risk of fire. The DC conductors of the PV module must be labeled "PV Wire" or "PV Cable" when paired with the Enphase microinverter.
	<b>WARNING:</b> You must match the DC operating voltage range of the PV module with the allowable input voltage range of the Enphase microinverter.
	<b>WARNING:</b> The maximum open circuit voltage of the PV module must not exceed the specified maximum input DC voltage of the Enphase microinverter. Refer to the Enphase Compatibility Calculator at: <a href="https://enphase.com/en-us/support/module-compatibility">https://enphase.com/en-us/support/module-compatibility</a> to verify PV module electrical compatibility with the microinverter. Use IQ8 Series microinverters only with compatible PV modules according to the Enphase compatibility calculator. Using electrically incompatible PV module voids Enphase warranty.
	<b>WARNING:</b> Risk of equipment damage. Install the microinverter under the PV module to avoid direct exposure to rain, UV, and other harmful weather events. Always install the microinverter bracket side up. Do not mount the microinverter upside down. Do not expose the AC or DC connectors (on the IQ Cable connection, PV module, or the microinverter) to rain or condensation before mating the connectors.

	<b>WARNING:</b> Risk of equipment damage. The Enphase microinverter is not protected from damage due to moisture trapped in cabling systems. Never mate microinverters to cables that have been left disconnected and exposed to wet conditions. This voids the Enphase warranty.
	<b>WARNING:</b> Risk of equipment damage. The Enphase microinverter functions only with a standard, compatible PV module with appropriate fill-factor, voltage, and current ratings. Unsupported devices include smart PV modules, fuel cells, wind or water turbines, DC generators, non-Enphase batteries, and so on. These devices do not behave like standard PV modules, so operation and compliance is not guaranteed. These devices may also damage the Enphase microinverter by exceeding its electrical rating, making the system potentially unsafe.

	<b>WARNING:</b> Risk of skin burn. The chassis of the Enphase microinverter is the heat sink. Under normal operating conditions, the temperature could be 20°C above ambient, but under extreme conditions the microinverter can reach a temperature of 90°C. To reduce risk of burns, use caution when working with microinverters.
	<b>NOTE:</b> The Enphase microinverter has adjustable voltage and frequency trip points that may need to be set within grid profile, depending upon local requirements. Contact Enphase Support to request a new custom grid profile if there is no pre-existing grid profile meeting local AHJ requirements.

### IQ Cable safety

	<b>DANGER:</b> Risk of electric shock. Do not install the IQ Terminator while power is connected.
	<b>DANGER:</b> Risk of electric shock. Risk of fire. When stripping the sheath from the IQ Cable, ensure the conductors are not damaged. If the exposed wires are damaged, the system may not function properly.
	<b>DANGER:</b> Risk of electric shock. Risk of fire. Do not leave AC connectors on the IQ Cable uncovered for an extended period. You must cover any unused connector with a sealing cap.
	<b>DANGER:</b> Risk of electric shock. Risk of fire. Make sure protective sealing caps have been installed on all unused AC connectors. Unused AC connectors are live when the system is energized.
	<b>WARNING:</b> Use the terminator only once. If you open the terminator following installation, the latching mechanism is destroyed. Do not reuse the terminator. If the latching mechanism is defective, do not use the terminator. Do not circumvent or manipulate the latching mechanism.
	<b>WARNING:</b> When installing the IQ Cable, secure any loose cable to minimize tripping hazards.
	<b>NOTE:</b> When looping the IQ Cable, do not form loops smaller than 12 cm (4.75 inches) in diameter.
	<b>NOTE:</b> If you need to remove a sealing cap, you must use the IQ Disconnect Tool.
	<b>NOTE:</b> When installing the IQ Cable and accessories, adhere to the following: <ul style="list-style-type: none"> <li>Do not expose the terminator or cable connections to directed, pressurized liquid (water jets, and so on).</li> <li>Do not expose the terminator or cable connections to continuous immersion.</li> <li>Do not expose the terminator or cable connections to continuous tension (for example, tension due to pulling or bending the cable near the connection).</li> <li>Use only the connectors and cables provided.</li> <li>Do not allow contamination or debris in the connectors.</li> <li>Use the terminator and cable connections only when all parts are present and intact.</li> <li>Do not install or use in potentially explosive environments.</li> <li>Do not allow the terminator to come into contact with open flame.</li> <li>Fit the terminator using only the prescribed tools and in the prescribed manner.</li> <li>Use the terminator to seal the conductor end of the Enphase IQ Cable; no other method is allowed.</li> </ul>

### DC cable safety

	<b>NOTE:</b> Ensure proper routing of PV Module DC cable using the clips to prevent the leads from resting on the roof. Do not wrap extra DC cable around microinverter.
	<b>NOTE:</b> Avoid direct exposure to sunlight.
	<b>NOTE:</b> Avoid sharp edges on racking.
	<b>NOTE:</b> Avoid cable touching rough surfaces or moving parts within the racking system.
	<b>NOTE:</b> Avoid overly tight bending radii. Minimum bend radii for the DC cable is eight times the outer diameter or 85 mm.
	<b>NOTE:</b> Avoid overly tightly sized IQ Cable Clips for routing.